



VRF SYSTEM

رؤيتنا

عملاؤنا وشركاؤنا الكرام ،

يُسعدنا أن نتوجّه إليكم بهذه الكلمة التي تعبّر عن اعتزازنا بما حققناه وتُجسّد مسيرة شركتنا في مجال توريد أنظمة التكييف، وتعكس التزامنا الراسخ بتقديم منتجات وحلول عالية الجودة ترتقي إلى تطلعات عملائنا وتواكب التطورات التقنية في هذا القطاع الحيوي .

منذ تأسيس شركة فاريز للتجارة والتسويق، جعلنا الثقة والتميز والجودة ركائز أساسية في جميع أعمالنا ، وحرصنا على تحقيق أعلى معايير الأداء والكفاءة في كل منتج نقدمه.

نحن نؤمن بأنّ النجاح الحقيقي يقوم على الشراكة طويلة الأمد مع عملائنا، وعلى تقديم قيمة حقيقية تضمن لهم الراحة، والكفاءة، والابتكار في كل مشروع نقوم به معاً .

إننا في شركة فاريز للتجارة و التسويق نواصل اليوم ما بدأناه من التزام بالتطوير المستمر، واضعين نصب أعيننا هدفاً واحداً: أن نكون الخيار الأفضل في حلول أنظمة التكييف في السوق المحلي .

مع خالص التقدير،

المدير العام

محمد بن عبدالرحمن الخضير

GROUP PROFILE

MANDO is a distinguished name in ventilation and air conditioning solutions and home appliances. More than twenty years and MANDO products serve at least 100,000 customers annually.

MANDO air conditioners are characterized by aesthetic design, quality performance and energy saving which are the ideal choice for economical devices.

MANDO is a registered trademark of FAREAZ Trading and Marketing.

WARRANTY

A comprehensive warranty for two years is provided on all MANDO air conditioners and seven years on the compressor and the customer must bring the purchase invoice, and maintenance requests are received on the united line of the MANDO air conditioners maintenance center 8001240402



QUALITY CERTIFICATES

MANDO air conditioners have obtained many international accreditation and certifications, MANDO air conditioners engineers are constantly developing MANDO products and keeping up with all new in the world of ventilation and air conditioning and always striving to achieve the requirements of our customers.

MAINTENANCE

MANDO has a fleet of technical support teams consisting of more than 50 technical teams equipped with full physical and knowledge equipment, and they are professionally managed by the maintenance and technical support center for MANDO located in the company's headquarters.





Product Lineup

Modular VRF Outdoor Unit

MANDO M7 : Scroll Series

Capacity	(kW)	25.2	28.0	33.5	40.0	45.0	50.4	56.0	61.5	68.0	73.5	78.5	85.0	90.0	95.2	101
	(HP)	8	10	12	14	16	18	20	22	24	26	28	30	32	34	36



8/10/12HP

14/16HP



18/20/22HP

24/26/28/30/32/34/36HP



38-72HP

74-108HP



110-144HP



Product Lineup

Mini VRF Outdoor Unit

Capacity(kW)	10	12	14	16	18	20	22
--------------	----	----	----	----	----	----	----

MANDO Mini



	•	•	•	•	•	•	•
--	---	---	---	---	---	---	---

Indoor Unit(DC)

Capacity(kW)	Appearance	1.5	2.2	2.8	3.6	4.5	5.6	6.3	7.1	8.0	9.0	10.0	11.0	11.2	12.5	14.0	15.0	16.0
--------------	------------	-----	-----	-----	-----	-----	-----	-----	-----	-----	-----	------	------	------	------	------	------	------

Compact
Cassette



	•	•	•	•	•	•												
--	---	---	---	---	---	---	--	--	--	--	--	--	--	--	--	--	--	--

Cassette Q



			•	•	•	•	•	•	•	•	•	•		•	•	•			•
--	--	--	---	---	---	---	---	---	---	---	---	---	--	---	---	---	--	--	---

Slim Duct(Q)



	•	•	•	•	•	•			•										
--	---	---	---	---	---	---	--	--	---	--	--	--	--	--	--	--	--	--	--

Mid ESP Duct



						•	•		•	•	•	•		•	•	•	•	•	•
--	--	--	--	--	--	---	---	--	---	---	---	---	--	---	---	---	---	---	---

Wall-mounted J



	•	•	•	•	•	•			•										
--	---	---	---	---	---	---	--	--	---	--	--	--	--	--	--	--	--	--	--

Wall-mounted C



		•	•	•	•	•			•	•	•	•	•						
--	--	---	---	---	---	---	--	--	---	---	---	---	---	--	--	--	--	--	--

Ceiling&Floor



			•	•	•	•			•	•	•	•		•	•	•			
--	--	--	---	---	---	---	--	--	---	---	---	---	--	---	---	---	--	--	--

Capacity(kW)	Appearance	22.4	28.0
--------------	------------	------	------

High ESP Duct



		•	•
--	--	---	---

Fresh Air Processor



		•	•
--	--	---	---

AHU Kit

Mode	Appearance	ARVK-0B	ARVK-00B	ARVK-01B	ARVK-02B	ARVK-03B
------	------------	---------	----------	----------	----------	----------

ARVK

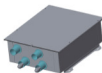

	•	•	•	•	•
--	---	---	---	---	---

Product Lineup

Indoor Unit

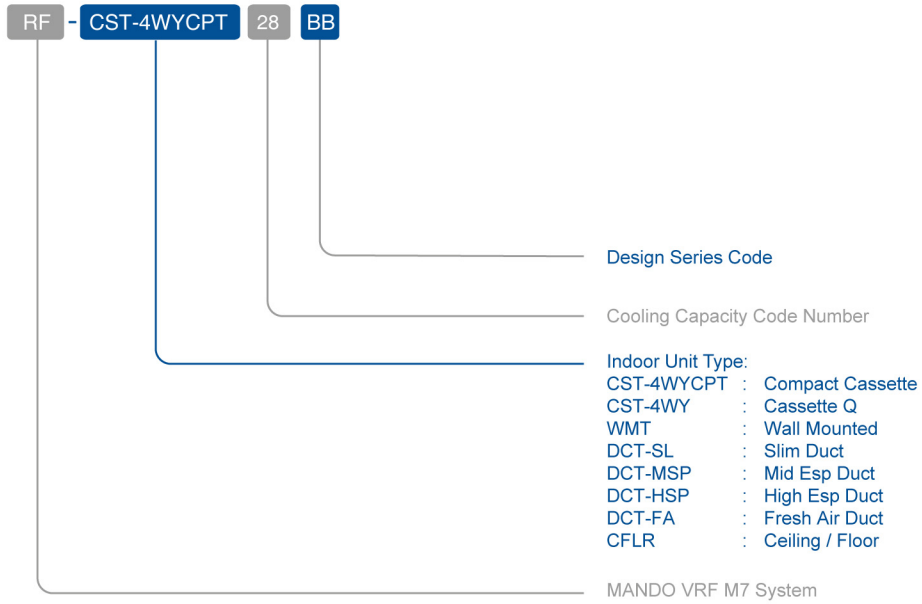

NOTE : Indoor Unit Power Supply : 220 - 240 V, 50 / 60 hz, 1 ph

Outdoor Unit

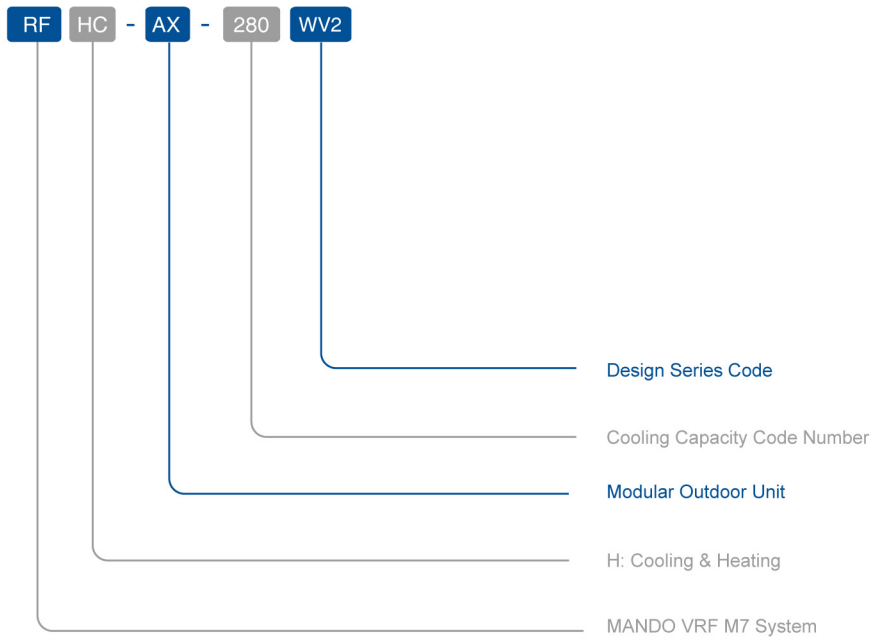

NOTE : Outdoor Unit Power Supply : 360 - 415 V, 50/60 Hz, 3 ph

MANDO M7 Series

All DC Inverter Mando VRF System



Feature MANDO M7 Series

VER Technology

► Variable Energy-efficiency Regulation

Evaporating and condensing temperature makes strong effect to the cooling and heating performance and energy-efficiency ratio of AC system.

Thanks to VER technology, MANDO M7 series has various modes with different refrigerant temperature which lead the system to different performance and energy-efficiency ratio.

Cooling: 3 modes with different evaporating temperature.

Heating: 3 modes with different condensing temperature.

Turbo mode

High cooling and heating performance, cool down or warm up the room rapidly.

Basic mode

Default mode, balance the reaction speed and efficiency.

High efficiency mode

Satisfy the lowest capacity requirement and low the energy consumption.

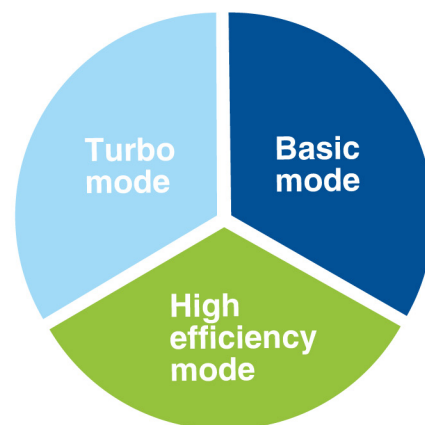

Users can choose a certain mode according to the actual need in different area and climate, so that the system can satisfy various requirement, and the seasonal efficiency can be optimized.

High Efficiency and Energy Saving

► High EER and COP

MANDO M7 Series achieves the industry's top class energy efficiency in cooling and heating by utilizing all DC inverter compressors, and Enhanced vapor injection.

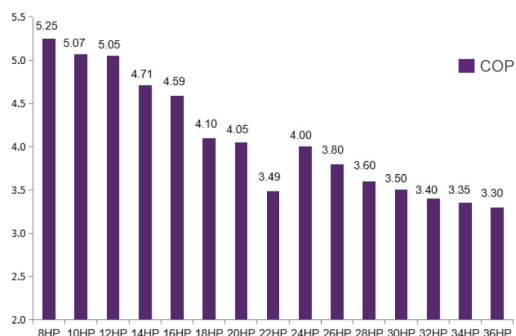
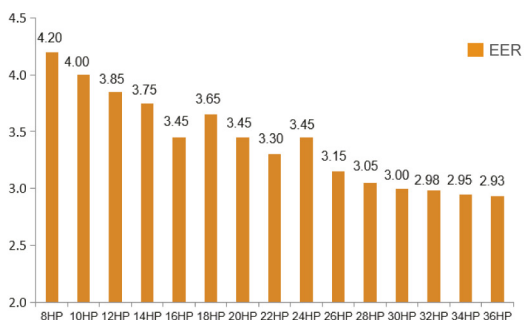

* Data from certification report: ERP, certification number: AHEE211200054953

► 180° Sine Wave Control

DC inverter compressor users 180° sine wave vector control technique makes motor operate smooth and increases the efficiency, significantly compared with traditional sawtooth wave. It also can lower the noise level.

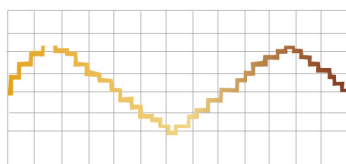

Traditional Control

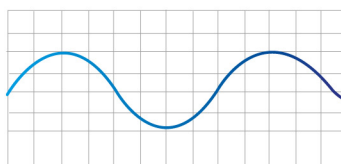

180° Sine Wave DC Control

► High efficiency DC fan motor

The DC brushless motor adjusts the fan speed according to the system pressure and operating load, resulting in a significant increase in efficiency, and the Super Aero fan provides greater air volume and higher static pressure



► Enhanced Vapor Injection DC Inverter Compressor

EVI-Enhanced vapor injection

Heating condition, reducing the outlet temperature, increasing the compressor capacity, improving the heating performance.

Optimize the asymmetric vortex design

Heating condition, reducing the outlet temperature, increasing the compressor capacity, improving the heating performance.

Dynamic oil balance structure

Oil balance tube implementation parallel compressor and oil quantity dynamic equilibrium, ensuring the reliability of several parallel compressors.

High efficiency motor configuration

Using high quality material concentrated stator, cooperate with neodymium magnet rotor, having outstanding efficiency.

High pressure cavity structure

Large exhaust buffer volume, reducing the air flow noise and vibration of the runtime.

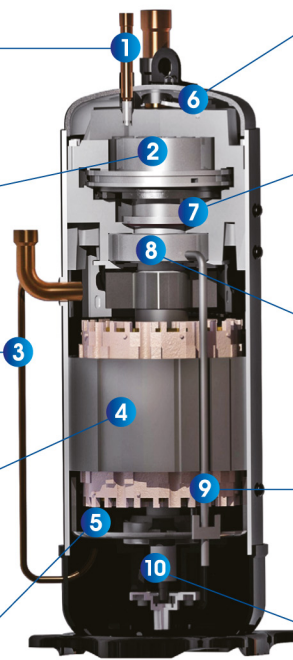

Pressure relief valve structure

Improving the partial load efficiency, adapt to the transformer ratio working condition, improving the compressor performance.

The intermediate pressure servo mechanism

According to the operation pressure among dynamic adjusting middle pressure, has realized the axial flexible, optimization of dynamic vortex disk meshing, improve product performance.

High reliability of the bearing

Adopt cylinder bearing and self-aligning ball bearing bearing group, improving the reliability of the compressor.

Internal oil circulation structure

Lubricating oil to achieve internal circulation, reducing heat loss, decreasing the rate of spitting oil, improve the efficiency and reliability.

Positive displacement gear oil pump

Positive displacement gear oil pump to ensure the high and low frequency can satisfy the oil supply, improving the reliability of the compressor.

► High-efficient permanent magnetic motors are installed, giving better performance than traditional DC inverter compressors.

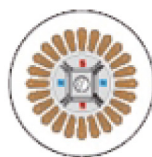

Centralizing winding

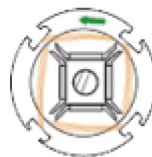

Distributed winding

Better performance and smaller size than traditional DC inverter compressors.

► High Efficient Heat Exchanger

Optimized 2 to 1 refrigerant circuit design, increase the heat exchanging efficiency and enhance the ratio of liquid which flow to the evaporator.

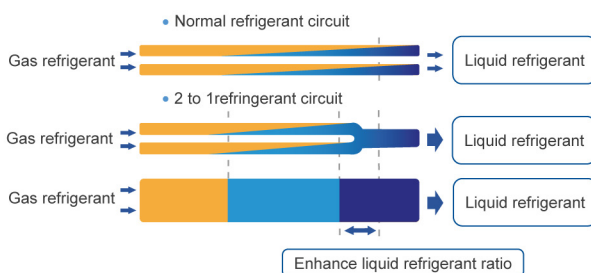

► Optimized fin design, reduces the water resistance and the wind resistance.

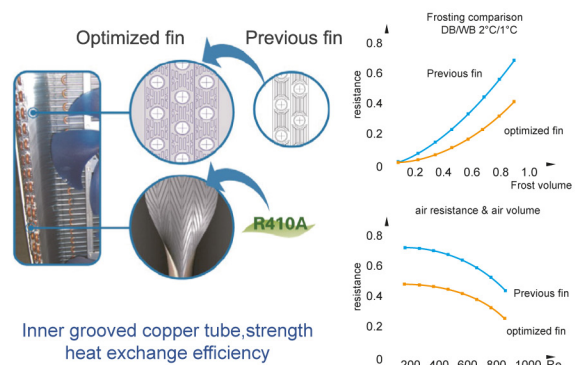

► 2-stage Sub-cooling Technology

The first stage sub-cooling process due to optimized refrigerant circuit and "Inverse fin type" window fin design.

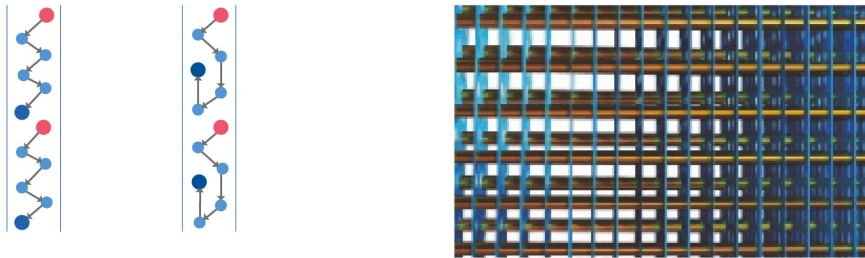

"Inverse fin type" window fin design

The second stage sub-cooling process by a high efficiency plate heat exchanger with a sub-cooling EXV.

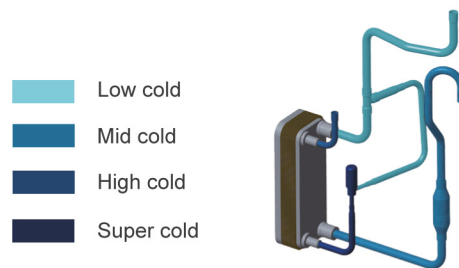

► 4-times Anticipation Energy-saving Control Technology

Module anticipation energy-saving control technology

In partial load, intelligent judgment single operation and the efficiency of the module keep the minimum power consumption.



Compressor anticipation energy-saving adjustment technology

Control compressors quantity and operating frequency, to get higher energy efficiency ratio in partial load.



Fan anticipation energy-saving adjustment technology

Control running quantity and operating frequency, obtain higher energy efficiency ratio under partial load.



Refrigerant anticipation energy-saving technology adjustment

Adjust the opening of the electronic expansion valve, to improve the effect of condenser heat transfer, to get higher energy efficiency ratio under partial load.

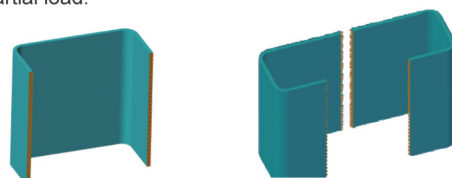

Wide Application Range

► Large Capacity & Free Combination

15 basic models from 8HP to 36HP.
Less quantity of system, space saving, easy installation and low cost.



► Wide Operation Range

No matter in hot summer or cold winter, MANDO M7 Series can supply comfortable environment for users.



*Performance Lab, June 13, 2023

► Wide Voltage Design

In Country with unstable voltage, MANDO M7 system still could run stably.

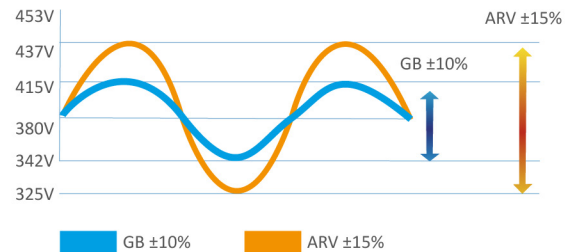

*Performance Laboratory on January 30, 2024

► Changeable ESP

The optimized fan can provide outdoor units with static pressures of up to 70Pa (8-22HP) and 80Pa (24-36HP), which can be installed on the service floor or facility room.

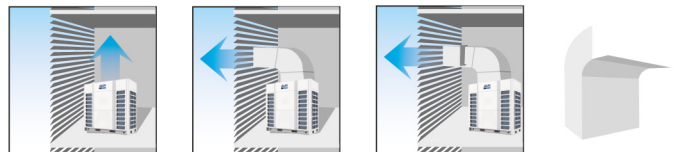

*Performance Laboratory on June 13, 2024

► Long Piping Length

Thanks to the DC inverter control technology and sub-cooling circuit technology, it is possible to design a system with longer piping and elevation difference which make it easier to design and installation.

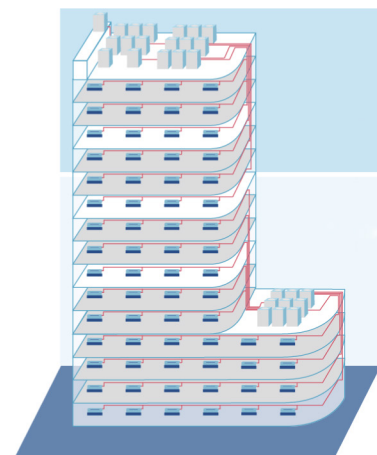

Comfortable And Healthy Environment

► 12 levels silent modes

"6-levels night silent modes.
6-levels daytime silent modes".

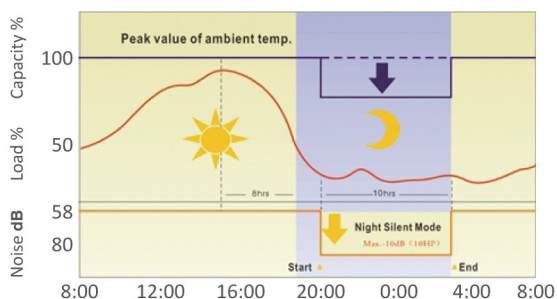

*Laboratory on November 15, 2022

Indoor Unit Quiet Mode

Innovative centrifugal fan for large diameter and a new design of the spiral duct system equipped with high-quality motor at the same time, making the air supply more quietly and smoothly.

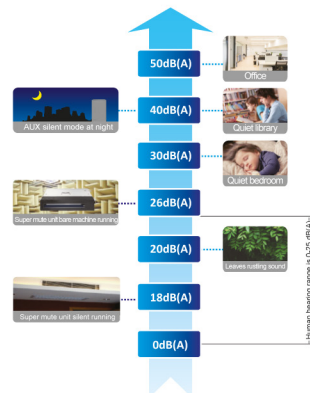

► Intelligent Defrosting

Variable parameters defrost through temperature and pressure sensors, to grasp time accurately which can defrost or heat normally.

Base on the main unit and at the end of the EXV control the output, fast bolt in liquid refrigerant system, unit operation is more stable; Through the dry run, defrosting exhaust temperature higher, more complete, more conventional. The defrosting time less 3 min than others at least.

Refrigerant pipeline design to ensure outdoor heat exchanger bottom no frost during heating and ice water mixture discharge smoothly when defrosting.

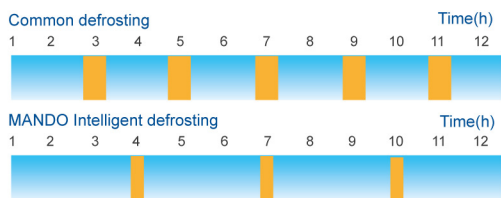

Normal air conditioner

MANDO M7 Series

► Fast Warm Up And Cool Down

The DC Inverter Compressor system reaches full load rapidly providing less temperature fluctuation and an improved living environment, bring great user experience.

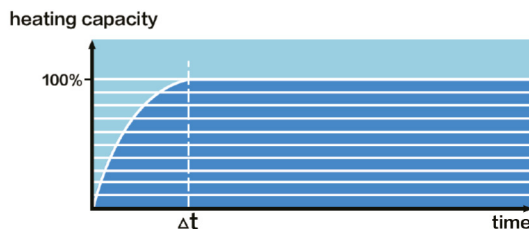

► Precise Temperature Control

Adopting composite temperature control technology, the set temperature can reach $\pm 0.5\text{ }^{\circ}\text{C}$.



► Humanization Design

VIP Function

Special VIP control function, the VIP room will decide the whole system operation mode, prior to other mode or economic locking function, ensure the priority of the important room.

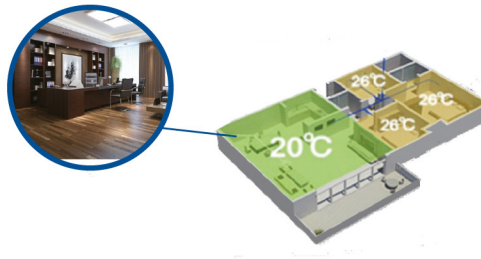

Auto Restart Function

The AC can automatically memorize the operation setting when power is cut off accidentally. It can return to previous setting when power resumes.

Recover the former operation state when power is restored, no need restart the unit manually

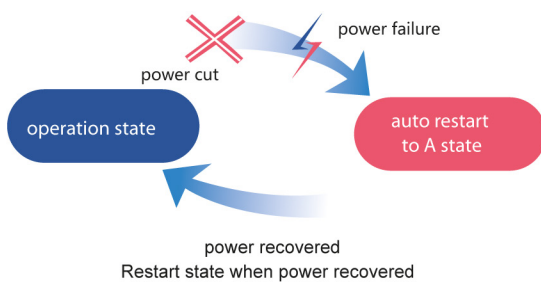

Economic Locking Function

Special design economic locking function, through outdoor PCB switch setting. If work in economic lock, AC lowest work cooling temperature will keep in 26°C and highest heating temperature keep 20°C .



Easy Installation & Maintenance

► Installation space saving

The MANDO M7 Series has larger capacity and smaller size, the capacity of the single unit can reach 36HP. For many large projects, the benefits of space-saving are particularly obvious.

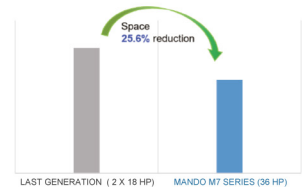

► No Oil Balance Pipe Between ODUS

High efficient oil/gas separating tech, make the system oil balance between compressors without oil balance pipe.

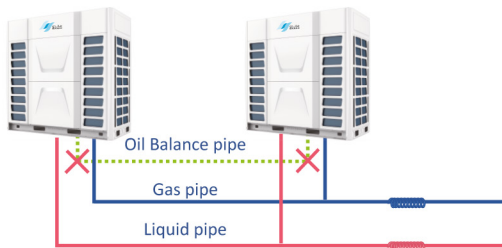

► Non-Polar Communication

Non-polar communication between IDUs, easy installation and commissioning.

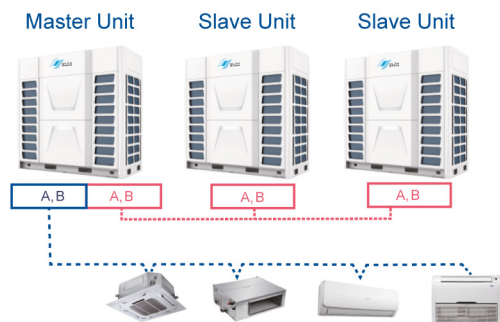

► Centralized controller without Mini gateway

MANDO M7 Series doesn't need Mini Gateway to connect CC02 or BMS system, making installation easier and more convenient.

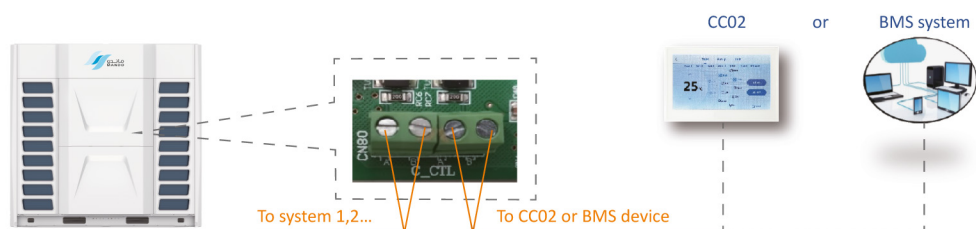

Same function: CC02(Max.64 systems&256 indoor units); MODBUS(Max.255 systems)

► Auto Commissioning

When commissioning, the outdoor mainboard can check the operation state and show the corresponding error code in engineering mode.

Find out the faults when commissioning, enhance the reliability of the system.

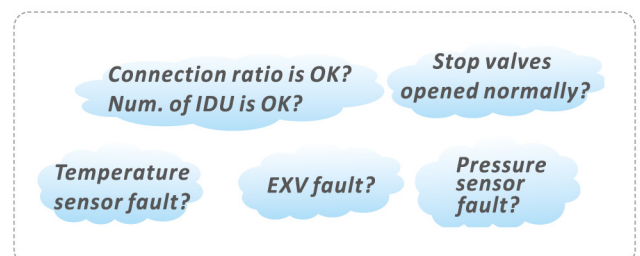

▶ Auto Refrigerant Recycling & Auto Refrigerant Charging

Refrigerant can be recycled to the outdoor units when maintenance is needed.

The outdoor unit can adjust the refrigerant amount according to the operation parameters such as pressure and temperature, and remind the installation personnel to stop charging.



▶ One Button Test Run

Press the button lightly once in the main PCB board of the master ODU, to realize the cooling and heating test run, don't need to open indoor machine one by one.

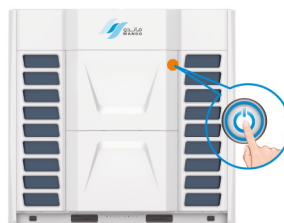

▶ Auto Dust Removal & Auto Snow-Blowing

The outdoor fan can rotate in reverse direction to remove dust on heat exchanger to ensure the heat exchange performance.



▶ Black BOX Function

Using aviation grade Black BOX technique, memorizing operation parameters before the failure, finding fault information quickly, as an accurate, efficient maintenance services to provide valuable information, maintenance more convenient.



▶ Pipe-connecting Mode

MANDO M7 Series can be on the front, left side, right side to choose pipe-connecting direction freely, it's easy to install.



Reliable & Stable

▶ Seven-levels of limit electricity usage

The unit has the function of energy saving and power limiting (40% - 100% output power limit). Users can choose the automatic energy saving mode. The system optimizes the output based on changes in ambient temperature, improving the comprehensive operating energy efficiency of the unit.

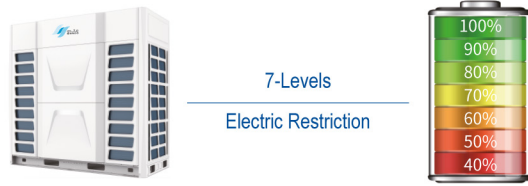

* Laboratory on November 20, 2022.

▶ EPS(emergency power source) control

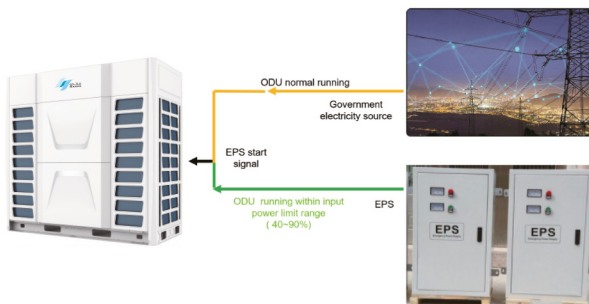

If Government electricity abnormal ,will start the EPS to supply electricity.

▶ Refrigerant PCB Cooling System

The PCB is well cooled by the refrigerant, ensuring the system operate steadily even in tropical area. Frequency limit of inverter compressor can be relaxed, so that the output capacity of ODU can be higher than conventional products.

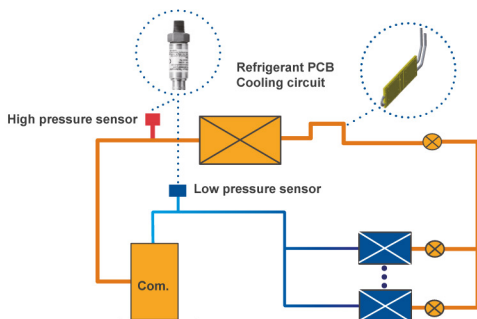

▶ Precise Refrigerant Control

Real-time monitoring the discharge and suction pressure of the system.

The output of compressors and the EXV open degree can be regulated precisely to optimize the compression ratio. Ensuring the compression ratio always in safety zone.

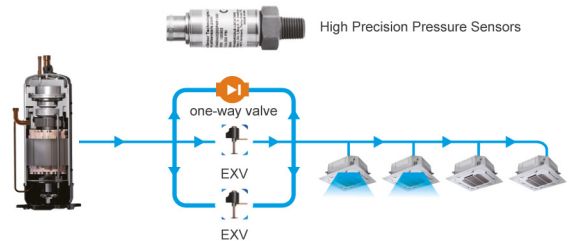

▶ Module Alternate Operation

In one combination system,any module could run as the master unit according to the running time.Balance the life of the outdoor units in one system.



► Back-Up Operation Technology

Module Emergency

As one module breaks down, module emergency can be set, then the rest modules in same combination can run normally.

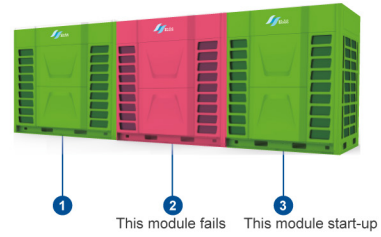

Compressor Emergency

As one compressor breaks down, compressor emergency can be set, then another compressor in this unit can run normally.

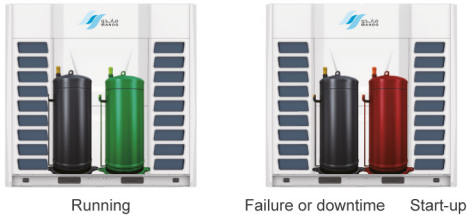

Fan motor backup.

Allowing time for maintenance or repair while comfort remains guaranteed.

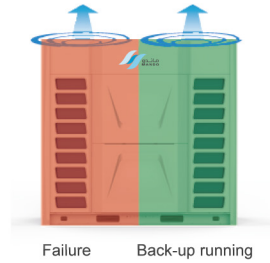

► All-round Protection

- High pressure protection
- Low pressure protection
- High compression ratio protection
- Low compression ratio protection
- High discharge temp. protection
- Low discharge temp. protection



- Voltage protection
- Current protection
- Fan motor protection
- Inverter module protection
- Compressor overload protection
- Phase sequence protection

Ground protection

► Shell reinforcement design

1. Integrated side plate, 4-sided bottom beam
2. The triangle is stable to prevent deformation of the side plate
3. Resistance to lateral shear force, preventing separation of chassis and crossbeam
4. Large fillet, reinforced support to prevent distortion and deformation

► Oil Return Control Technology

Dynamic Oil Return Control Technology

Monitor compressor running state and running time, computing system reasonable oil return time.

6-Step Oil Separating Technology

Completely solve the problem of oil, the system more stable and reliable

Compressor Throwing Oil Technology

When the compressor oil level higher than the warning line, system through tubing eliminate redundant frozen oil, keep the oil balance between compressor.

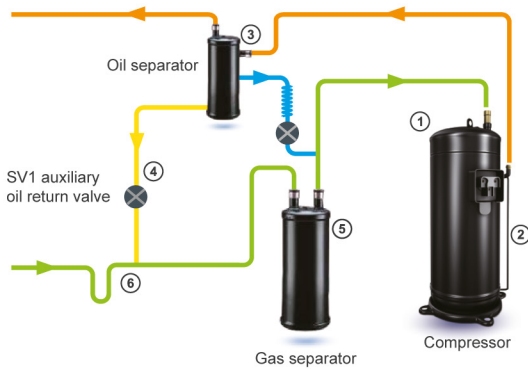

- ① Compressor with oil mist separation
- ② Oil self balancing control design
- ③ High efficient oil separator
- ④ Emergency oil circuit design
- ⑤ Gas-liquid separator oil return
- ⑥ System with oil return design

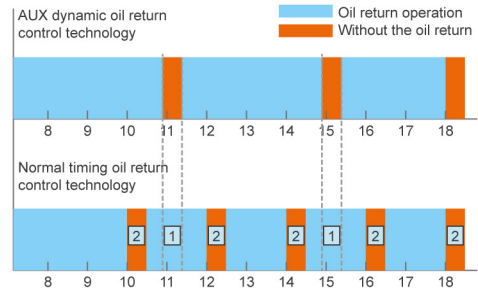

- 1 Need oil return but there was no oil return operation, which can't guarantee the system stability and reliability.
- 2 Without oil return operation is to carry on the oil return operation, which cause unnecessary waste.

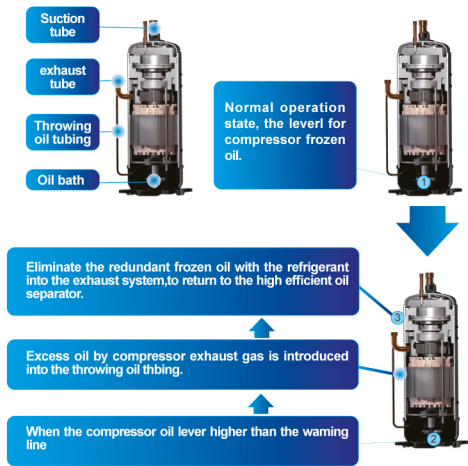

► Three-phase relay

the ODU can be equipped with three-phase relays to effectively protect the PCB from voltage fluctuations.

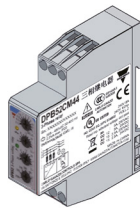

► Complete Solutions

Provide diversified solutions, including VRF selection software, BIM models, and CFD simulations.



MANDO M7 Series

Flexible Outdoor Unit Combination															
HP	8	10	12	14	16	18	20	22	24	26	28	30	32	34	36
38				★					★						
40				★						★					
42					★					★					
44						★				★					
46							★			★					
48								★		★					
50									★	★					
52										★★					
54						★									★
56							★								★
58								★							★
60									★						★
62										★					★
64											★				★
66												★			★
68													★		★
70														★	★
72															★★
74				★					★						★
76				★						★					★
78					★					★					★
80						★				★					★
82							★			★					★
84								★		★					★
86									★	★					★
88										★★					★
90						★									★★

*The above combination types are factory-recommended type. The combined type also can be combined at will.



MANDO M7 Series

Flexible Outdoor Unit Combination															
HP	8	10	12	14	16	18	20	22	24	26	28	30	32	34	36
92							★								★★
94								★							★★
96									★						★★
98										★					★★
100											★				★★
102												★			★★
104													★		★★
106														★	★★
108															★★★
110										★★★			★		
112										★★	★		★		
114										★★		★	★		
116										★★			★★		
118										★	★		★★		
120										★		★	★★		
122										★			★★★		
124											★		★★★		
126												★	★★★		
128													★★★★		
130								★							★★★
132									★						★★★
134										★					★★★
136											★				★★★
138												★			★★★
140													★		★★★
142														★	★★★
144															★★★★

*The above combination types are factory-recommended type. The combined type also can be combined at will.

MANDO M7 Series

MANDO M7 Series 380~415V-50/60Hz

HP			8	10	12	14
Model			RFHC-AX-252 WV2	RFHC-AX-280 WV2	RFHC-AX-335 WV2	RFHC-AX-400 WV2
Power Supply	V~,Hz,Ph		380~415,50/60,3	380~415,50/60,3	380~415,50/60,3	380~415,50/60,3
Capacity	Cooling(T1)	kW	25.2	27.9	33.3	40.0
		Btu/h	86000	95000	114000	136000
	Cooling(T3)	kW	22.2	24.9	29.4	33.6
		Btu/h	76000	85000	100000	114000
Heating	kW	25.2	27.9	33.3	40.0	
	Btu/h	86000	95000	114000	136000	
Electric Data	Rated Cooling Power Input(T1)	kW	5.99	6.98	8.62	10.67
	Rated Cooling Power Input(T3)	kW	7.55	9.02	10.24	11.62
	Rated Heating Power Input(T1)	kW	4.8	5.5	6.6	8.5
Performance	EER(T1)	W/W	4.20	4.00	3.85	3.75
		Btu/(h*W)	14.35	13.65	13.15	12.80
	EER(T3)	W/W	2.95	2.75	2.85	2.90
		Btu/(h*W)	10.05	9.40	9.75	9.90
COP (T1)	W/W	5.25	5.07	5.05	4.71	
Refrigerant type	Type		R410a	R410a	R410a	R410a
Compressor	Quantity		1	1	1	1
	Type		DC Inverter	DC Inverter	DC Inverter	DC Inverter
Fan motor	Type		DC Inverter	DC Inverter	DC Inverter	DC Inverter
	Quantity		1	1	1	2
Max.No.of Indoor Units	unit		13	14	17	19
Air Flow Volume	CFM		7059	7059	7059	8235
	m3/h		12000	12000	12000	14000
Sound Pressure level	dB(A)		58	58	58	61
Dimension (WxDxH)	Net	mm	990×765×1635	990×765×1635	990×765×1635	1340×765×1635
	Packing	mm	1030×825×1865	1030×825×1865	1030×825×1865	1395×815×1865
Weight	Net	kg	215	215	230	265
	Gross	kg	225	225	240	280
Piping limitations	Max. Length	m	1000	1000	1000	1000
	Max. Height	m	110/130	110/130	110/130	110/130
Ambient Temp (Cooling/Heating)	°C		-10~55/-20~24	-10~55/-20~24	-10~55/-20~24	-10~55/-20~24

MANDO M7 Series 380~415V-50/60Hz

HP			16	18	20	22
Model			RFHC-AX-450 WV2	RFHC-AX-500 WV2	RFHC-AX-560 WV2	RFHC-AX-615 WV2
Power Supply	V~,Hz,Ph		380~415,50/60,3	380~415,50/60,3	380~415,50/60,3	380~415,50/60,3
Capacity	Cooling(T1)	kW	45.0	50.0	56.0	61.5
		Btu/h	154000	170000	192000	210000
	Cooling(T3)	kW	37.2	42.0	44.0	46.0
		Btu/h	127000	144000	150000	156000
Heating	kW	45.0	50.0	56.0	61.5	
	Btu/h	154000	170000	192000	210000	
Electric Data	Rated Cooling Power Input(T1)	kW	13.04	13.70	16.14	18.64
	Rated Cooling Power Input(T3)	kW	13.73	15.73	17.05	18.4
	Rated Heating Power Input(T1)	kW	9.8	12.2	13.83	17.6
Performance	EER(T1)	W/W	3.45	3.65	3.45	3.30
		Btu/(h*W)	11.80	12.45	11.80	11.25
	EER(T3)	W/W	2.70	2.65	2.60	2.50
		Btu/(h*W)	9.20	9.05	8.85	8.55
COP (T1)	W/W	4.59	4.10	4.05	3.49	
Refrigerant type	Type		R410a	R410a	R410a	R410a
Compressor	Quantity		1	2	2	2
	Type		DC Inverter	DC Inverter	DC Inverter	DC Inverter
Fan motor	Type		DC Inverter	DC Inverter	DC Inverter	DC Inverter
	Quantity		2	2	2	2
Max.No.of Indoor Units	unit		22	23	26	27
Air Flow Volume	CFM		8235	9412	9412	9412
	m3/h		14000	16000	16000	16000
Sound Pressure level	dB(A)		61	63	63	63
Dimension (WxDxH)	Net	mm	1340×765×1635	1340×765×1635	1340×765×1635	1340×765×1635
	Packing	mm	1395×815×1865	1395×815×1865	1395×815×1865	1395×815×1865
Weight	Net	kg	265	330	330	330
	Gross	kg	280	345	345	345
Piping limitations	Max. Length	m	1000	1000	1000	1000
	Max. Height	m	110/130	110/130	110/130	110/130
Ambient Temp (Cooling/Heating)	°C		-10~55/-20~24	-10~55/-20~24	-10~55/-20~24	-10~55/-20~24

Notes:

- 1.Cooling Capacity: Indoor temperature 27°C DB/19°C WB; Outdoor temperature:T1:35°C DB. T3:46°C DB
- 2.Heating Capacity: Indoor temperature 20°C DB; Outdoor temperature: 7°C DB/ 6°C WB.
- 3.Piping Length: Equivalent piping length: 7.5m, level difference: 0m.
- 4.We can guarantee the operation only within 130% Combination. If you want to connect more than 130% combination, please contact us and discuss the requirement.
- 5.Sound values are measured in a semi-anechoic room, at a position 1m in front of the unit and 1.3m above the floor.

Remarks:

- 1.Data may change according to test surroundings, reserves right of explanation on data.
- 2.All specifications are subject to change by the manufacturer without prior notice

MANDO M7 Series 380~415V-50/60Hz

HP			24	26	28	30	
Model			RFHC-AX-670 WV2	RFHC-AX-730 WV2	RFHC-AX-785 WV2	RFHC-AX-850 WV2	
Power Supply	V~,Hz,Ph		380~415,50/60,3	380~415,50/60,3	380~415,50/60,3	380~415,50/60,3	
Capacity	Cooling(T1)	kW	67.0	73.0	78.5	85.0	
		Btu/h	228000	250000	268000	290000	
	Cooling(T3)	kW	52.0	57.0	61.0	63.5	
		Btu/h	178000	194000	208000	216000	
Heating	kW	67.0	73.0	78.5	85.0		
	Btu/h	228000	250000	268000	290000		
Electric Data	Rated Cooling Power Input(T1)		kW	19.42	23.17	25.74	28.33
	Rated Cooling Power Input(T3)		kW	20	22.35	24.4	25.6
	Rated Heating Power Input(T1)		kW	16.8	19.1	21.8	24.3
Performance	EER(T1)	W/W	3.45	3.15	3.05	3.00	
		Btu/(h*W)	11.75	10.80	10.40	10.25	
	EER(T3)	W/W	2.60	2.55	2.50	2.48	
		Btu/(h*W)	8.90	8.70	8.50	8.45	
COP (T1)		W/W	4.00	3.80	3.60	3.50	
Refrigerant type	Type		R410a	R410a	R410a	R410a	
Compressor	Quantity		2	2	2	2	
	Type		DC Inverter	DC Inverter	DC Inverter	DC Inverter	
Fan motor	Type		DC Inverter	DC Inverter	DC Inverter	DC Inverter	
	Quantity		2	2	2	2	
Max.No.of Indoor Units	unit		30	33	36	37	
Air Flow Volume	CFM		17059	17059	17059	17647	
	m3/h		29000	29000	29000	30000	
Sound Pressure level	dB(A)		62	62	63	64	
Dimension (WxDxH)	Net	mm	1850×825×1760	1850×825×1760	1850×825×1760	1850×825×1760	
	Packing	mm	1925×930×1930	1925×930×1930	1925×930×1930	1925×930×1930	
Weight	Net	kg	388	388	388	422	
	Gross	kg	411	411	411	445	
Piping limitations	Max. Length	m	1000	1000	1000	1000	
	Max. Height	m	110/130	110/130	110/130	110/130	
Ambient Temp (Cooling/Heating)	°C		-10~55/-20~24	-10~55/-20~24	-10~55/-20~24	-10~55/-20~24	

MANDO M7 Series 380~415V-50/60Hz

HP			32	34	36	
Model			RFHC-AX-900 WV2	RFHC-AX-950 WV2	RFHC-AX-1010 WV2	
Power Supply	V~,Hz,Ph		380~415,50/60,3	380~415,50/60,3	380~415,50/60,3	
Capacity	Cooling(T1)	kW	90.0	95.0	101.0	
		Btu/h	308000	324000	344000	
	Cooling(T3)	kW	65.0	67.5	71.5	
		Btu/h	222000	230000	244000	
Heating	kW	90.0	95.0	101.0		
	Btu/h	308000	324000	344000		
Electric Data	Rated Cooling Power Input(T1)		kW	30.20	32.20	34.47
	Rated Cooling Power Input(T3)		kW	26.53	27.89	29.79
	Rated Heating Power Input(T1)		kW	26.5	28.4	30.4
Performance	EER(T1)	W/W	2.98	2.95	2.93	
		Btu/(h*W)	10.20	10.05	10.00	
	EER(T3)	W/W	2.45	2.42	2.40	
		Btu/(h*W)	8.35	8.25	8.20	
COP (T1)		W/W	3.40	3.35	3.30	
Refrigerant type	Type		R410a	R410a	R410a	
Compressor	Quantity		2	2	2	
	Type		DC Inverter	DC Inverter	DC Inverter	
Fan motor	Type		DC Inverter	DC Inverter	DC Inverter	
	Quantity		2	2	2	
Max.No.of Indoor Units	unit		38	39	42	
Air Flow Volume	CFM		17647	17647	17647	
	m3/h		30000	30000	30000	
Sound Pressure level	dB(A)		64	66	66	
Dimension (WxDxH)	Net	mm	1850×825×1760	1850×825×1760	1850×825×1760	
	Packing	mm	1925×930×1930	1925×930×1930	1925×930×1930	
Weight	Net	kg	422	430	430	
	Gross	kg	445	453	453	
Piping limitations	Max. Length	m	1000	1000	1000	
	Max. Height	m	110/130	110/130	110/130	
Ambient Temp (Cooling/Heating)	°C		-10~55/-20~24	-10~55/-20~24	-10~55/-20~24	

Notes:

- Cooling Capacity: Indoor temperature 27°C DB/19°C WB; Outdoor temperature:T1:35°C DB. T3:46°C DB
- Heating Capacity: Indoor temperature 20°C DB; Outdoor temperature: 7°C DB/ 6°C WB.
- Piping Length: Equivalent piping length: 7.5m, level difference: 0m.
- We can guarantee the operation only within 130% Combination. If you want to connect more than 130% combination, please contact us and discuss the requirement.
- Sound values are measured in a semi-anechoic room, at a position 1m in front of the unit and 1.3m above the floor.

Remarks:

- Data may change according to test surroundings, reserves right of explanation on data.
- All specifications are subject to change by the manufacturer without prior notice.

MANDO M7 Series 380~415V-50/60Hz

HP			38	40	42	44	46
Model			RFHC-AX-1060 WV2	RFHC-AX-1120 WV2	RFHC-AX-1170 WV2	RFHC-AX-1230 WV2	RFHC-AX-1280 WV2
Power Supply	V~,Hz,Ph		380~415,50/60,3	380~415,50/60,3	380~415,50/60,3	380~415,50/60,3	380~415,50/60,3
Capacity	Cooling(T1)	kW	107.0	113.0	118.0	123.0	129.0
		Btu/h	365000	385000	402000	419000	440000
	Cooling(T3)	kW	85.6	90.6	94.2	99.0	101.0
		Btu/h	292000	309000	321000	337000	344000
Heating	kW	107.0	113.0	118.0	123.0	129.0	
	Btu/h	365000	385000	402000	419000	440000	
Electric Data	Rated Cooling Power Input(T1)	kW	30.09	33.84	36.21	36.87	39.31
	Rated Cooling Power Input(T3)	kW	31.62	33.97	36.08	38.08	39.4
	Rated Heating Power Input(T1)	kW	25.3	27.6	28.9	31.3	32.93
Performance	EER(T1)	W/W	3.56	3.34	3.26	3.34	3.28
		Btu/(h*W)	12.13	11.39	11.12	11.38	11.20
	EER(T3)	W/W	2.71	2.67	2.61	2.60	2.56
		Btu/(h*W)	9.24	9.10	8.91	8.87	8.75
COP (T1)	W/W	4.23	4.09	4.08	3.93	3.92	
Refrigerant type	Type		R410a	R410a	R410a	R410a	R410a
Compressor	Quantity		3	3	3	4	4
	Type		DC Inverter	DC Inverter	DC Inverter	DC Inverter	DC Inverter
Fan motor	Type		DC Inverter	DC Inverter	DC Inverter	DC Inverter	DC Inverter
	Quantity		4	4	4	4	4
Max.No.of Indoor Units	unit		50	53	55	58	59
Air Flow Volume	CFM		17059+8235	17059+8235	17059+8235	17059+9412	17059+9412
	m3/h		29000+14000	29000+14000	29000+14000	29000+16000	29000+16000
Sound Pressure level	dB(A)		62	62	62	63	63
Dimension (WxDxH)	Net	mm	1850×825×1760+ 1340×765×1635	1850×825×1760+ 1340×765×1635	1850×825×1760+ 1340×765×1635	1850×825×1760+ 1340×765×1635	1850×825×1760+ 1340×765×1635
	Packing	mm	1925×930×1930+ 1395×815×1865	1925×930×1930+ 1395×815×1865	1925×930×1930+ 1395×815×1865	1925×930×1930+ 1395×815×1865	1925×930×1930+ 1395×815×1865
Weight	Net	kg	388+265	388+265	388+265	388+330	388+330
	Gross	kg	411+280	411+280	411+280	411+345	411+345
Piping limitations	Max. Length	m	1000	1000	1000	1000	1000
	Max. Height	m	110/130	110/130	110/130	110/130	110/130
Ambient Temp (Cooling/Heating)	°C		-10~55/-20~24	-10~55/-20~24	-10~55/-20~24	-10~55/-20~24	-10~55/-20~24

MANDO M7 Series 380~415V-50/60Hz

HP			48	50	52	54
Model			RFHC-AX-1340 WV2	RFHC-AX-1400 WV2	RFHC-AX-1450 WV2	RFHC-AX-1510 WV2
Power Supply	V~,Hz,Ph		380~415,50/60,3	380~415,50/60,3	380~415,50/60,3	380~415,50/60,3
Capacity	Cooling(T1)	kW	134.5	140.0	146.0	151.0
		Btu/h	459000	477000	498000	515000
	Cooling(T3)	kW	103.0	109.0	114.0	113.5
		Btu/h	351000	372000	389000	387000
Heating	kW	134.5	140.0	146.0	151.0	
	Btu/h	459000	477000	498000	515000	
Electric Data	Rated Cooling Power Input(T1)	kW	41.81	42.59	46.34	48.17
	Rated Cooling Power Input(T3)	kW	40.75	42.35	44.7	45.52
	Rated Heating Power Input(T1)	kW	36.7	35.9	38.2	42.6
Performance	EER(T1)	W/W	3.22	3.29	3.15	3.13
		Btu/(h*W)	10.98	11.22	10.75	10.70
	EER(T3)	W/W	2.53	2.57	2.55	2.49
		Btu/(h*W)	8.62	8.78	8.70	8.51
COP (T1)	W/W	3.66	3.90	3.82	3.54	
Refrigerant type	Type		R410a	R410a	R410a	R410a
Compressor	Quantity		4	4	4	4
	Type		DC Inverter	DC Inverter	DC Inverter	DC Inverter
Fan motor	Type		DC Inverter	DC Inverter	DC Inverter	DC Inverter
	Quantity		4	4	4	4
Max.No.of Indoor Units	unit		60	64	64	64
Air Flow Volume	CFM		17059+9412	17059*2	17059*2	17647+9412
	m3/h		29000+16000	29000*2	29000*2	30000+16000
Sound Pressure level	dB(A)		63	62	62	66
Dimension (WxDxH)	Net	mm	1850×825×1760+ 1340×765×1635	(1850×825×1760)*2	(1850×825×1760)*2	1850×825×1760+ 1340×765×1635
	Packing	mm	1925×930×1930+ 1395×815×1865	(1925×930×1930)*2	(1925×930×1930)*2	1925×930×1930+ 1395×815×1865
Weight	Net	kg	388+330	388*2	388*2	430+330
	Gross	kg	411+345	411*2	411*2	453+345
Piping limitations	Max. Length	m	1000	1000	1000	1000
	Max. Height	m	110/130	110/130	110/130	110/130
Ambient Temp (Cooling/Heating)	°C		-10~55/-20~24	-10~55/-20~24	-10~55/-20~24	-10~55/-20~24

Notes:

- Cooling Capacity: Indoor temperature 27°C DB/19°C WB; Outdoor temperature:T1:35°C DB. T3:46°C DB
- Heating Capacity: Indoor temperature 20°C DB; Outdoor temperature: 7°C DB/ 6°C WB.
- Piping Length: Equivalent piping length: 7.5m, level difference: 0m.
- We can guarantee the operation only within 130% Combination. If you want to connect more than 130% combination, please contact us and discuss the requirement.
- Sound values are measured in a semi-anechoic room, at a position 1m in front of the unit and 1.3m above the floor.

Remarks:

- Data may change according to test surroundings, reserves right of explanation on data.
- All specifications are subject to change by the manufacturer without prior notice.

MANDO M7 Series 380~415V-50/60Hz

HP			56	58	60	62	64	
Model			RFHC-AX-1560 WV2	RFHC-AX-1624 WV2	RFHC-AX-1680 WV2	RFHC-AX-1730 WV2	RFHC-AX-1790 WV2	
Power Supply	V~,Hz,Ph		380~415,50/60,3	380~415,50/60,3	380~415,50/60,3	380~415,50/60,3	380~415,50/60,3	
Capacity	Cooling(T1)	kW	157.0	162.5	168.0	174.0	179.5	
		Btu/h	535000	554000	573000	593000	612000	
	Cooling(T3)	kW	115.5	117.5	123.5	128.5	132.5	
		Btu/h	394000	401000	421000	438000	452000	
Heating	kW	157.0	162.5	168.0	174.0	179.5		
	Btu/h	535000	554000	573000	593000	612000		
Electric Data	Rated Cooling Power Input(T1)		kW	50.61	53.11	53.89	57.64	60.21
	Rated Cooling Power Input(T3)		kW	46.84	48.19	49.79	52.14	54.19
	Rated Cooling Power Input(T3)		kW	44.23	48	47.2	49.5	52.2
Performance	EER(T1)	W/W	3.10	3.06	3.12	3.02	2.98	
		Btu/(h*W)	10.58	10.44	10.64	10.30	10.17	
	EER(T3)	W/W	2.47	2.44	2.48	2.46	2.45	
		Btu/(h*W)	8.41	8.32	8.46	8.41	8.34	
COP (T1)		W/W	3.55	3.39	3.56	3.52	3.44	
Refrigerant type	Type		R410a	R410a	R410a	R410a	R410a	
Compressor	Quantity		4	4	4	4	4	
	Type		DC Inverter	DC Inverter	DC Inverter	DC Inverter	DC Inverter	
Fan motor	Type		DC Inverter	DC Inverter	DC Inverter	DC Inverter	DC Inverter	
	Quantity		4	4	4	4	4	
Max.No.of Indoor Units	unit		64	64	64	64	64	
Air Flow Volume	CFM		17647+9412	17647+9412	17647+17059	17647+17059	17647+17059	
	m3/h		30000+16000	30000+16000	30000+29000	30000+29000	30000+29000	
Sound Pressure level	dB(A)		66	66	66	66	66	
Dimension (WxDxH)	Net		mm	1850×825×1760+1340×765×1635	1850×825×1760+1340×765×1635	(1850×825×1760)*2	(1850×825×1760)*2	(1850×825×1760)*2
	Packing		mm	1925×930×1930+1395×815×1865	1925×930×1930+1395×815×1865	(1925×930×1930)*2	(1925×930×1930)*2	(1925×930×1930)*2
Weight	Net		kg	430+330	430+330	430+388	430+388	430+388
	Gross		kg	453+345	453+345	453+411	453+411	453+411
Refrigerant Pipe	Max. Length		m	1000	1000	1000	1000	1000
	Max. Height		m	110/130	110/130	110/130	110/130	110/130
Ambient Temp (Cooling/Heating)	°C		-10~55/-20~24	-10~55/-20~24	-10~55/-20~24	-10~55/-20~24	-10~55/-20~24	

MANDO M7 Series 380~415V-50/60Hz

HP			66	68	70	72	
Model			RFHC-AX-1840 WV2	RFHC-AX-1900 WV2	RFHC-AX-1960 WV2	RFHC-AX-2010 WV2	
Power Supply	V~,Hz,Ph		380~415,50/60,3	380~415,50/60,3	380~415,50/60,3	380~415,50/60,3	
Capacity	Cooling(T1)	kW	186.0	191.0	196.0	202.0	
		Btu/h	634000	651000	668000	689000	
	Cooling(T3)	kW	135.0	136.5	139.0	143.0	
		Btu/h	460000	465000	474000	488000	
Heating	kW	186.0	191.0	196.0	202.0		
	Btu/h	634000	651000	668000	689000		
Electric Data	Rated Cooling Power Input(T1)		kW	62.80	64.67	66.67	68.94
	Rated Cooling Power Input(T3)		kW	55.39	56.32	57.68	59.58
	Rated Heating Power Input(T1)		kW	54.7	56.9	58.8	60.8
Performance	EER(T1)	W/W	2.96	2.95	2.94	2.93	
		Btu/(h*W)	10.11	10.08	10.03	10.00	
	EER(T3)	W/W	2.44	2.42	2.41	2.40	
		Btu/(h*W)	8.32	8.27	8.22	8.19	
COP (T1)		W/W	3.40	3.36	3.33	3.32	
Refrigerant type	Type		R410a	R410a	R410a	R410a	
Compressor	Quantity		4	4	4	4	
	Type		DC Inverter	DC Inverter	DC Inverter	DC Inverter	
Fan motor	Type		DC Inverter	DC Inverter	DC Inverter	DC Inverter	
	Quantity		4	4	4	4	
Max.No.of Indoor Units	unit		64	64	64	64	
Air Flow Volume	CFM		17647*2	17647*2	17647*2	17647*2	
	m3/h		30000*2	30000*2	30000*2	30000*2	
Sound Pressure level	dB(A)		66	66	66	66	
Dimension (WxDxH)	Net		mm	(1850×825×1760)*2	(1850×825×1760)*2	(1850×825×1760)*2	(1850×825×1760)*2
	Packing		mm	(1925×930×1930)*2	(1925×930×1930)*2	(1925×930×1930)*2	(1925×930×1930)*2
Weight	Net		kg	430+422	430+422	430*2	430*2
	Gross		kg	453+445	453+445	453*2	453*2
Piping limitations	Max. Length		m	1000	1000	1000	1000
	Max. Height		m	110/130	110/130	110/130	110/130
Ambient Temp (Cooling/Heating)	°C		-10~55/-20~24	-10~55/-20~24	-10~55/-20~24	-10~55/-20~24	

Notes:

- Cooling Capacity: Indoor temperature 27°C DB/19°C WB; Outdoor temperature: T1:35°C DB. T3:46°C DB
- Heating Capacity: Indoor temperature 20°C DB; Outdoor temperature: 7°C DB/ 6°C WB.
- Piping Length: Equivalent piping length: 7.5m, level difference: 0m.
- We can guarantee the operation only within 130% Combination. If you want to connect more than 130% combination, please contact us and discuss the requirement.
- Sound values are measured in a semi-anechoic room, at a position 1m in front of the unit and 1.3m above the floor.

Remarks:

- Data may change according to test surroundings, reserves right of explanation on data.
- All specifications are subject to change by the manufacturer without prior notice.

MANDO M7 Series 380~415V-50/60Hz

HP			74	76	78	80	82
Model			RFHC-AX-2070 WV2	RFHC-AX-2120 WV2	RFHC-AX-2180 WV2	RFHC-AX-2240 WV2	RFHC-AX-2290 WV2
Power Supply	V~,Hz,Ph		380~415,50/60,3	380~415,50/60,3	380~415,50/60,3	380~415,50/60,3	380~415,50/60,3
Capacity	Cooling(T1)	kW	208.0	214.0	219.0	224.0	230.0
		Btu/h	709000	730000	747000	764000	784000
	Cooling(T3)	kW	157.1	162.1	165.7	170.5	172.5
		Btu/h	536000	553000	565000	581000	588000
Heating	kW	208.0	214.0	219.0	224.0	230.0	
	Btu/h	709000	730000	747000	764000	784000	
Electric Data	Rated Cooling Power Input(T1)	kW	64.56	68.31	70.68	71.34	73.78
	Rated Cooling Power Input(T3)	kW	61.41	63.76	65.87	67.87	69.19
	Rated Heating Power Input(T1)	kW	55.7	58	59.3	61.7	63.33
Performance	EER(T1)	W/W	3.22	3.13	3.10	3.14	3.12
		Btu/(h*W)	10.99	10.69	10.57	10.71	10.64
	EER(T3)	W/W	2.56	2.54	2.52	2.51	2.49
		Btu/(h*W)	8.73	8.67	8.58	8.57	8.51
COP (T1)	W/W	3.73	3.69	3.69	3.63	3.63	
Refrigerant type	Type		R410a	R410a	R410a	R410a	
Compressor	Quantity		5	5	5	6	6
	Type		DC Inverter	DC Inverter	DC Inverter	DC Inverter	DC Inverter
Fan motor	Type		DC Inverter	DC Inverter	DC Inverter	DC Inverter	DC Inverter
	Quantity		6	6	6	6	6
Max.No.of Indoor Units	unit		64	64	64	64	64
Air Flow Volume	CFM		17647+17059+8235	17647+17059+8235	17647+17059+8235	17647+17059+9412	17647+17059+9412
	m3/h		30000+29000+14000	30000+29000+14000	30000+29000+14000	30000+29000+16000	30000+29000+16000
Sound Pressure level	dB(A)		66	66	66	66	66
Dimension (WxDxH)	Net	mm	(1850×825×1760)*2+ 1340×765×1635	(1850×825×1760)*2+ 1340×765×1635	(1850×825×1760)*2+ 1340×765×1635	(1850×825×1760)*2+ 1340×765×1635	(1850×825×1760)*2+ 1340×765×1635
	Packing	mm	(1925×930×1930)*2+ 1395×815×1865	(1925×930×1930)*2+ 1395×815×1865	(1925×930×1930)*2+ 1395×815×1865	(1925×930×1930)*2+ 1395×815×1865	(1925×930×1930)*2+ 1395×815×1865
Weight	Net	kg	430+388+265	430+388+265	430+388+265	430+388+330	430+388+330
	Gross	kg	453+411+280	453+411+280	453+411+280	453+411+345	453+411+345
Piping limitations	Max. Length	m	1000	1000	1000	1000	1000
	Max. Height	m	110/130	110/130	110/130	110/130	110/130
Ambient Temp (Cooling/Heating)	°C		-10~55/-20~24	-10~55/-20~24	-10~55/-20~24	-10~55/-20~24	-10~55/-20~24

MANDO M7 Series 380~415V-50/60Hz

HP			84	86	88	90
Model			RFHC-AX-2350 WV2	RFHC-AX-2400 WV2	RFHC-AX-2460 WV2	RFHC-AX-2520 WV2
Power Supply	V~,Hz,Ph		380~415,50/60,3	380~415,50/60,3	380~415,50/60,3	380~415,50/60,3
Capacity	Cooling(T1)	kW	235.5	241.0	247.0	252.0
		Btu/h	803000	822000	842000	859000
	Cooling(T3)	kW	174.5	180.5	185.5	185.0
		Btu/h	595000	616000	633000	631000
Heating	kW	235.5	241.0	247.0	252.0	
	Btu/h	803000	822000	842000	859000	
Electric Data	Rated Cooling Power Input(T1)	kW	76.28	77.06	80.81	82.64
	Rated Cooling Power Input(T3)	kW	70.54	72.14	74.49	75.31
	Rated Heating Power Input(T1)	kW	67.1	66.3	68.6	73
Performance	EER(T1)	W/W	3.09	3.13	3.06	3.05
		Btu/(h*W)	10.53	10.67	10.43	10.40
	EER(T3)	W/W	2.47	2.50	2.49	2.46
		Btu/(h*W)	8.44	8.54	8.50	8.38
COP (T1)	W/W	3.51	3.63	3.60	3.45	
Refrigerant type	Type		R410a	R410a	R410a	R410a
Compressor	Quantity		6	6	6	6
	Type		DC Inverter	DC Inverter	DC Inverter	DC Inverter
Fan motor	Type		DC Inverter	DC Inverter	DC Inverter	DC Inverter
	Quantity		6	6	6	6
Max.No.of Indoor Units	unit		64	64	64	64
Air Flow Volume	CFM		17647+17059+9412	17647+17059*2	17647+17059*2	17647*2+9412
	m3/h		30000+29000+16000	30000+29000*2	30000+29000*2	30000*2+16000
Sound Pressure level	dB(A)		66	66	66	66
Dimension (WxDxH)	Net	mm	(1850×825×1760)*2+ 1340×765×1635	(1850×825×1760)*3	(1850×825×1760)*3	(1850×825×1760)*2+ 1340×765×1635
	Packing	mm	(1925×930×1930)*2+ 1395×815×1865	(1925×930×1930)*3	(1925×930×1930)*3	(1925×930×1930)*2+ 1395×815×1865
Weight	Net	kg	430+388+330	430+388*2	430+388*2	430*2+330
	Gross	kg	453+411+345	453+411*2	453+411*2	453*2+345
Piping limitations	Max. Length	m	1000	1000	1000	1000
	Max. Height	m	110/130	110/130	110/130	110/130
Ambient Temp (Cooling/Heating)	°C		-10~55/-20~24	-10~55/-20~24	-10~55/-20~24	-10~55/-20~24

Notes:

- Cooling Capacity: Indoor temperature 27°C DB/19°C WB; Outdoor temperature: T1:35°C DB. T3:46°C DB
- Heating Capacity: Indoor temperature 20°C DB; Outdoor temperature: 7°C DB/ 6°C WB.
- Piping Length: Equivalent piping length: 7.5m, level difference: 0m.
- We can guarantee the operation only within 130% Combination. If you want to connect more than 130% combination, please contact us and discuss the requirement.
- Sound values are measured in a semi-anechoic room, at a position 1m in front of the unit and 1.3m above the floor.

Remarks:

- Data may change according to test surroundings, reserves right of explanation on data.
- All specifications are subject to change by the manufacturer without prior notice.

MANDO M7 Series 380~415V-50/60Hz

HP			92	94	96	98	100	
Model			RFHC-AX-2580 WV2	RFHC-AX-2630 WV2	RFHC-AX-2700 WV2	RFHC-AX-2750 WV2	RFHC-AX-2800 WV2	
Power Supply	V~, Hz, Ph		380~415, 50/60, 3	380~415, 50/60, 3	380~415, 50/60, 3	380~415, 50/60, 3	380~415, 50/60, 3	
Capacity	Cooling(T1)	kW	258.0	263.5	269.0	275.0	280.5	
		Btu/h	880000	899000	917000	938000	957000	
	Cooling(T3)	kW	187.0	189.0	195.0	200.0	204.0	
		Btu/h	638000	645000	665000	682000	696000	
Heating	kW	258.0	263.5	269.0	275.0	280.5		
	Btu/h	880000	899000	917000	938000	957000		
Electric Data	Rated Cooling Power Input(T1)		kW	85.08	87.58	88.36	92.11	94.68
	Rated Cooling Power Input(T3)		kW	76.63	77.98	79.58	81.93	83.98
	Rated Heating Power Input(T1)		kW	74.63	78.4	77.6	79.9	82.6
Performance	EER(T1)	WWW	3.03	3.01	3.04	2.99	2.96	
		Btu/(h*W)	10.35	10.27	10.39	10.19	10.11	
	EER(T3)	WWW	2.44	2.42	2.45	2.44	2.43	
		Btu/(h*W)	8.33	8.27	8.36	8.33	8.29	
COP (T1)		WWW	3.46	3.36	3.47	3.44	3.40	
Refrigerant type	Type		R410a	R410a	R410a	R410a		
Compressor	Quantity		6	6	6	6	6	
	Type		DC Inverter	DC Inverter	DC Inverter	DC Inverter	DC Inverter	
Fan motor	Type		DC Inverter	DC Inverter	DC Inverter	DC Inverter	DC Inverter	
	Quantity		6	6	6	6	6	
Max.No.of Indoor Units	unit		64	64	64	64	4	
Air Flow Volume	CFM		17647*2+9412	17647*2+9412	17647*2+17059	17647*2+17059	17647*2+17059	
	m3/h		30000*2+16000	30000*2+16000	30000*2+29000	30000*2+29000	30000*2+29000	
Sound Pressure level	dB(A)		66	66	66	66	66	
Dimension (WxDxH)	Net	mm	(1850×825×1760)*2+1340×765×1635	(1850×825×1760)*2+1340×765×1635	(1850×825×1760)*3	(1850×825×1760)*3	(1850×825×1760)*3	
	Packing	mm	(1925×930×1930)*2+1395×815×1865	(1925×930×1930)*2+1395×815×1865	(1925×930×1930)*3	(1925×930×1930)*3	(1925×930×1930)*3	
Weight	Net	kg	430*2+330	430*2+330	430*2+388	430*2+388	430*2+388	
	Gross	kg	453*2+345	453*2+345	453*2+411	453*2+411	453*2+411	
Piping limitations	Max. Length	m	1000	1000	1000	1000	1000	
	Max. Height	m	110/130	110/130	110/130	110/130	110/130	
Ambient Temp (Cooling/Heating)	°C		-10~55/-20~24	-10~55/-20~24	-10~55/-20~24	-10~55/-20~24	-10~55/-20~24	

MANDO M7 Series 380~415V-50/60Hz

HP			102	104	106	108	
Model			RFHC-AX-2870 WV2	RFHC-AX-2920 WV2	RFHC-AX-2970 WV2	RFHC-AX-3030 WV2	
Power Supply	V~, Hz, Ph		380~415, 50/60, 3	380~415, 50/60, 3	380~415, 50/60, 3	380~415, 50/60, 3	
Capacity	Cooling(T1)	kW	287.0	292.0	297.0	303.0	
		Btu/h	979000	996000	1013000	1033000	
	Cooling(T3)	kW	206.5	208.0	210.5	214.5	
		Btu/h	704000	709000	718000	732000	
Heating	kW	287.0	292.0	297.0	303.0		
	Btu/h	979000	996000	1013000	1033000		
Electric Data	Rated Cooling Power Input(T1)		kW	97.27	99.14	101.14	103.41
	Rated Cooling Power Input(T3)		kW	85.18	86.11	87.47	89.37
	Rated Heating Power Input(T1)		kW	85.1	87.3	89.2	91.2
Performance	EER(T1)	WWW	2.95	2.95	2.94	2.93	
		Btu/(h*W)	10.07	10.05	10.02	10.00	
	EER(T3)	WWW	2.42	2.42	2.41	2.40	
		Btu/(h*W)	8.27	8.24	8.21	8.19	
COP (T1)		WWW	3.37	3.34	3.33	3.32	
Refrigerant type	Type		R410a	R410a	R410a	R410a	
Compressor	Quantity		6	6	6	6	
	Type		DC Inverter	DC Inverter	DC Inverter	DC Inverter	
Fan motor	Type		DC Inverter	DC Inverter	DC Inverter	DC Inverter	
	Quantity		6	6	6	6	
Max.No.of Indoor Units	unit		64	64	64	64	
Air Flow Volume	CFM		17647*3	17647*3	17647*3	17647*3	
	m3/h		30000*3	30000*3	30000*3	30000*3	
Sound Pressure level	dB(A)		66	66	66	66	
Dimension (WxDxH)	Net	mm	(1850×825×1760)*3	(1850×825×1760)*3	(1850×825×1760)*3	(1850×825×1760)*3	
	Packing	mm	(1925×930×1930)*3	(1925×930×1930)*3	(1925×930×1930)*3	(1925×930×1930)*3	
Weight	Net	kg	430*2+422	430*2+422	430*3	430*3	
	Gross	kg	453*2+445	453*2+445	453*3	453*3	
Piping limitations	Max. Length	m	1000	1000	1000	1000	
	Max. Height	m	110/130	110/130	110/130	110/130	
Ambient Temp (Cooling/Heating)	°C		-10~55/-20~24	-10~55/-20~24	-10~55/-20~24	-10~55/-20~24	

Notes:

- 1.Cooling Capacity: Indoor temperature 27°C DB/19°C WB; Outdoor temperature:T1:35°C DB, T3:46°C DB
- 2.Heating Capacity: Indoor temperature 20°C DB; Outdoor temperature: 7°C DB/ 6°C WB.
- 3.Piping Length: Equivalent piping length: 7.5m, level difference: 0m.
- 4.We can guarantee the operation only within 130% Combination. If you want to connect more than 130% combination, please contact us and discuss the requirement.
- 5.Sound values are measured in a semi-anechoic room, at a position 1m in front of the unit and 1.3m above the floor.

Remarks:

- 1.Data may change according to test surroundings, reserves right of explanation on data.
- 2.All specifications are subject to change by the manufacturer without prior notice.

MANDO M7 Series 380~415V-50/60Hz

HP			110	112	114	116	118
Model			RFHC-AX-3090 WV2	RFHC-AX-3140 WV2	RFHC-AX-3210 WV2	RFHC-AX-3260 WV2	RFHC-AX-3310 WV2
Power Supply		V~,Hz,Ph	380~415,50/60,3	380~415,50/60,3	380~415,50/60,3	380~415,50/60,3	380~415,50/60,3
Capacity	Cooling(T1)	kW	309.0	314.5	321.0	326.0	331.5
		Btu/h	1054000	1073000	1095000	1112000	1131000
	Cooling(T3)	kW	236.0	240.0	242.5	244.0	248.0
Heating	Btu/h	805000	819000	827000	832000	846000	
	kW	309.0	314.5	321.0	326.0	331.5	
Electric Data	Rated Cooling Power Input(T1)	kW	99.71	102.28	104.87	106.74	109.31
		kW	93.58	95.63	96.83	97.76	99.81
	Rated Heating Power Input(T1)	kW	83.8	86.5	89	91.2	93.9
		W/W	3.10	3.07	3.06	3.05	3.03
Performance	EER(T1)	Btu/(h*W)	10.57	10.49	10.44	10.42	10.35
		W/W	2.52	2.51	2.50	2.50	2.48
	EER(T3)	Btu/(h*W)	8.60	8.56	8.54	8.52	8.48
COP (T1)	W/W	3.69	3.64	3.61	3.57	3.53	
Refrigerant type	Type		R410a	R410a	R410a	R410a	
Compressor	Quantity		8	8	8	8	
	Type		DC Inverter	DC Inverter	DC Inverter	DC Inverter	
Fan motor	Type		DC Inverter	DC Inverter	DC Inverter	DC Inverter	
	Quantity		8	8	8	8	
Max.No.of Indoor Units		unit	64	64	64	64	
Air Flow Volume	CFM		17647+17059*3	17647+17059*3	17647+17059*3	17647*2+17059*2	17647*2+17059*2
	m3/h		30000+29000*3	30000+29000*3	30000+29000*3	30000*2+29000*2	30000*2+29000*2
Sound Pressure level		dB(A)	64	64	64	64	
Dimension (WxDxH)	Net	mm	(1850×825×1760)*4	(1850×825×1760)*4	(1850×825×1760)*4	(1850×825×1760)*4	(1850×825×1760)*4
	Packing	mm	(1925×930×1930)*4	(1925×930×1930)*4	(1925×930×1930)*4	(1925×930×1930)*4	(1925×930×1930)*4
Weight	Net	kg	422+388*3	422+388*3	422*2+388*2	422*2+388*2	422*2+388*2
	Gross	kg	445+411*3	445+411*3	445*2+411*2	445*2+411*2	445*2+411*2
Piping limitations	Max. Length	m	1000	1000	1000	1000	1000
	Max. Height	m	110/130	110/130	110/130	110/130	110/130
Ambient Temp (Cooling/Heating)		°C	-10~55/-20~24	-10~55/-20~24	-10~55/-20~24	-10~55/-20~24	-10~55/-20~24

MANDO M7 Series 380~415V-50/60Hz

HP			120	122	124	126
Model			RFHC-AX-3380 WV2	RFHC-AX-3430 WV2	RFHC-AX-3480 WV2	RFHC-AX-3550 WV2
Power Supply		V~,Hz,Ph	380~415,50/60,3	380~415,50/60,3	380~415,50/60,3	380~415,50/60,3
Capacity	Cooling(T1)	kW	338.0	343.0	348.5	355.0
		Btu/h	1153000	1170000	1189000	1211000
	Cooling(T3)	kW	250.5	252.0	256.0	258.5
Heating	Btu/h	854000	860000	873000	882000	
	kW	338.0	343.0	348.5	355.0	
Electric Data	Rated Cooling Power Input(T1)	kW	111.90	113.77	116.34	118.93
		kW	101.01	101.94	103.99	105.19
	Rated Heating Power Input(T1)	kW	96.4	98.6	101.3	103.8
		W/W	3.02	3.01	3.00	2.98
Performance	EER(T1)	Btu/(h*W)	10.31	10.29	10.22	10.18
		W/W	2.48	2.47	2.46	2.46
	EER(T3)	Btu/(h*W)	8.46	8.43	8.40	8.38
COP (T1)	W/W	3.51	3.48	3.44	3.42	
Refrigerant type	Type		R410a	R410a	R410a	R410a
Compressor	Quantity		8	8	8	8
	Type		DC Inverter	DC Inverter	DC Inverter	DC Inverter
Fan motor	Type		DC Inverter	DC Inverter	DC Inverter	DC Inverter
	Quantity		8	8	8	8
Max.No.of Indoor Units		unit	64	64	64	64
Air Flow Volume	CFM		17647*3+17059	17647*3+17059	17647*3+17059	17647*4
	m3/h		30000*3+29000	30000*3+29000	30000*3+29000	30000*4
Sound Pressure level		dB(A)	64	64	64	64
Dimension (WxDxH)	Net	mm	(1850×825×1760)*4	(1850×825×1760)*4	(1850×825×1760)*4	(1850×825×1760)*4
	Packing	mm	(1925×930×1930)*4	(1925×930×1930)*4	(1925×930×1930)*4	(1925×930×1930)*4
Weight	Net	kg	422*3+388	422*3+388	422*3+388	422*4
	Gross	kg	445*3+411	445*3+411	445*3+411	445*4
Piping limitations	Max. Length	m	1000	1000	1000	1000
	Max. Height	m	110/130	110/130	110/130	110/130
Ambient Temp (Cooling/Heating)		°C	-10~55/-20~24	-10~55/-20~24	-10~55/-20~24	-10~55/-20~24

Notes:

- Cooling Capacity: Indoor temperature 27°C DB/19°C WB; Outdoor temperature:T1:35°C DB. T3:46°C DB
- Heating Capacity: Indoor temperature 20°C DB; Outdoor temperature: 7°C DB/ 6°C WB.
- Piping Length: Equivalent piping length: 7.5m, level difference: 0m.
- We can guarantee the operation only within 130% Combination. If you want to connect more than 130% combination, please contact us and discuss the requirement.
- Sound values are measured in a semi-anechoic room, at a position 1m in front of the unit and 1.3m above the floor.

Remarks:

- Data may change according to test surroundings, reserves right of explanation on data.
- All specifications are subject to change by the manufacturer without prior notice.

MANDO M7 Series 380~415V-50/60Hz

HP			128	130	132	134	136
Model			RFHC-AX-3600 WV2	RFHC-AX-3640 WV2	RFHC-AX-3710 WV2	RFHC-AX-3760 WV2	RFHC-AX-3810 WV2
Power Supply	V~, Hz, Ph		380~415,50/60,3	380~415,50/60,3	380~415,50/60,3	380~415,50/60,3	380~415,50/60,3
Capacity	Cooling(T1)	kW	360.0	364.5	370.0	376.0	381.5
		Btu/h	1228000	1243000	1262000	1283000	1301000
	Cooling(T3)	kW	260.0	260.5	266.5	271.5	275.5
		Btu/h	887000	889000	909000	926000	940000
Heating	kW	360.0	364.5	370.0	376.0	381.5	
	Btu/h	1228000	1243000	1262000	1283000	1301000	
Electric Data	Rated Cooling Power Input(T1)	kW	120.80	122.05	122.83	126.58	129.15
	Rated Cooling Power Input(T3)	kW	106.12	107.77	109.37	111.72	113.77
	Rated Cooling Power Input(T3)	kW	106	108.8	108	110.3	113
Performance	EER(T1)	WWW	2.98	2.99	3.01	2.97	2.95
		Btu/(h*W)	10.17	10.19	10.28	10.14	10.08
	EER(T3)	WWW	2.45	2.42	2.44	2.43	2.42
		Btu/(h*W)	8.36	8.25	8.31	8.29	8.26
COP (T1)	WWW	3.40	3.35	3.43	3.41	3.38	
Refrigerant type	Type		R410a	R410a	R410a	R410a	
Compressor	Quantity		8	8	8	8	8
	Type		DC Inverter	DC Inverter	DC Inverter	DC Inverter	DC Inverter
Fan motor	Type		DC Inverter	DC Inverter	DC Inverter	DC Inverter	DC Inverter
	Quantity		8	8	8	8	8
Max.No.of Indoor Units	unit		64	64	64	64	64
Air Flow Volume	CFM		17647*4	17647*3+9412	17647*3+17059	17647*3+17059	17647*3+17059
	m3/h		30000*4	30000*3+16000	30000*3+29000	30000*3+29000	30000*3+29000
Sound Pressure level	dB(A)		64	66	66	66	66
Dimension (WxDxH)	Net	mm	(1850*825*1760)*4	(1850*825*1760)*3+1340*765*1635	(1850*825*1760)*4	(1850*825*1760)*4	(1850*825*1760)*4
	Packing	mm	(1925*930*1930)*4	(1925*930*1930)*3+1395*815*1865	(1925*930*1930)*4	(1925*930*1930)*4	(1925*930*1930)*4
Weight	Net	kg	422*4	430*3+330	430*3+388	430*3+388	430*3+388
	Gross	kg	445*4	453*3+345	453*3+411	453*3+411	453*3+411
Refrigerant Pipe	Max. Length	m	1000	1000	1000	1000	1000
	Max. Height	m	110/130	110/130	110/130	110/130	110/130
Ambient Temp (Cooling/Heating)	°C		-10~55/-20~24	-10~55/-20~24	-10~55/-20~24	-10~55/-20~24	-10~55/-20~24

MANDO M7 Series 380~415V-50/60Hz

HP			138	140	142	144
Model			RFHC-AX-3880 WV2	RFHC-AX-3930 WV2	RFHC-AX-3980 WV2	RFHC-AX-4040 WV2
Power Supply	V~, Hz, Ph		380~415,50/60,3	380~415,50/60,3	380~415,50/60,3	380~415,50/60,3
Capacity	Cooling(T1)	kW	388.0	393.0	398.0	404.0
		Btu/h	1323000	1341000	1358000	1378000
	Cooling(T3)	kW	278.0	279.5	282.0	286.0
		Btu/h	948000	953000	962000	976000
Heating	kW	388.0	393.0	398.0	404.0	
	Btu/h	1323000	1341000	1358000	1378000	
Electric Data	Rated Cooling Power Input(T1)	kW	131.74	133.61	135.61	137.88
	Rated Cooling Power Input(T3)	kW	114.97	115.9	117.26	119.16
	Rated Heating Power Input(T1)	kW	115.5	117.7	119.6	121.6
Performance	EER(T1)	WWW	2.95	2.94	2.93	2.93
		Btu/(h*W)	10.05	10.04	10.01	10.00
	EER(T3)	WWW	2.42	2.41	2.40	2.40
		Btu/(h*W)	8.25	8.23	8.21	8.19
COP (T1)	WWW	3.36	3.34	3.33	3.32	
Refrigerant type	Type		R410a	R410a	R410a	R410a
Compressor	Quantity		8	8	8	8
	Type		DC Inverter	DC Inverter	DC Inverter	DC Inverter
Fan motor	Type		DC Inverter	DC Inverter	DC Inverter	DC Inverter
	Quantity		8	8	8	8
Max.No.of Indoor Units	unit		64	64	64	64
Air Flow Volume	CFM		17647*4	17647*4	17647*4	17647*4
	m3/h		30000*4	30000*4	30000*4	30000*4
Sound Pressure level	dB(A)		66	66	66	66
Dimension (WxDxH)	Net	mm	(1850*825*1760)*4	(1850*825*1760)*4	(1850*825*1760)*4	(1850*825*1760)*4
	Packing	mm	(1925*930*1930)*4	(1925*930*1930)*4	(1925*930*1930)*4	(1925*930*1930)*4
Weight	Net	kg	430*3+422	430*3+422	430*4	430*4
	Gross	kg	453*3+445	453*3+445	453*4	453*4
Piping limitations	Max. Length	m	1000	1000	1000	1000
	Max. Height	m	110/130	110/130	110/130	110/130
Ambient Temp (Cooling/Heating)	°C		-10~55/-20~24	-10~55/-20~24	-10~55/-20~24	-10~55/-20~24

Notes:

- Cooling Capacity: Indoor temperature 27°C DB/19°C WB; Outdoor temperature:T1:35°C DB. T3:46°C DB
- Heating Capacity: Indoor temperature 20°C DB; Outdoor temperature: 7°C DB/ 6°C WB.
- Piping Length: Equivalent piping length: 7.5m, level difference: 0m.
- We can guarantee the operation only within 130% Combination. If you want to connect more than 130% combination, please contact us and discuss the requirement.
- Sound values are measured in a semi-anechoic room, at a position 1m in front of the unit and 1.3m above the floor.

Remarks:

- Data may change according to test surroundings, reserves right of explanation on data.
- All specifications are subject to change by the manufacturer without prior notice.



MANDO Mini Series *All DC Inverter*

Feature

▶ DC Inverter Compressor

Made of rare earth permanent magnetic material, the rotor could change the motor's round speed by changing the DC voltage motor, thus overcome the electromagnetic noise and rotor loss of AC inverter compressor, then achieves high efficiency as well as low noise.

▶ Diversification of installation

A various of indoor units can be connected together, multi indoor units can be freely combined together in one systems . So Mini VRF is the best choose for some place which had multi rooms.

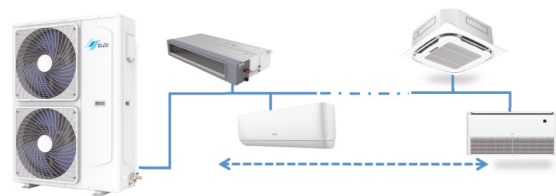

▶ Wide Voltage Design

In country with unstable voltage, ARV can also run stably.

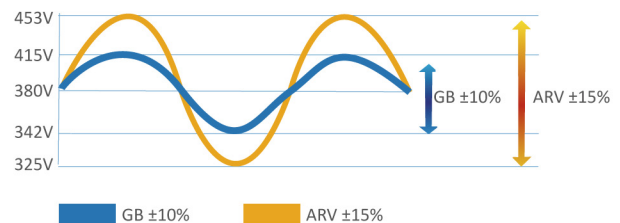

* Data Source: December 2024 MANDO Performance Lab.

▶ 26°C economic locking

All indoor units will run as energy saving mode state.



▶ Auto Restart Function

The AC can automatically memorize the operation setting when power is cut off accidentally. It can return to previous setting when power resumes.

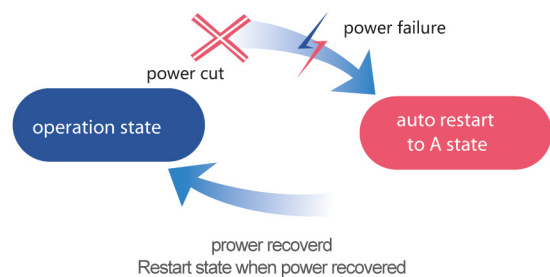

▶ Intelligent Defrosting

Intelligent defrosting technique extends the heating operation and decreases the frequency of defrosting. Results in stable room temperature, offering comfort life.

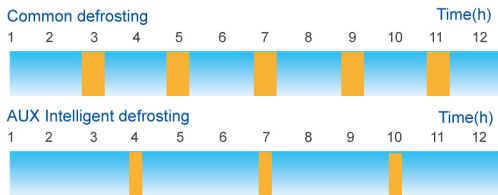

▶ Refrigerant PCB Cooling System

The PCB is well cooled by the refrigerant, ensuring the system operates steadily.

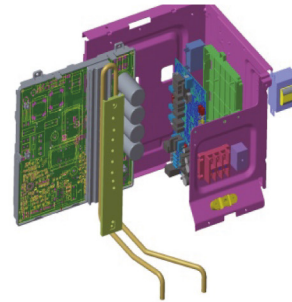

▶ NEW type Intergraded PCB design(2→1)

The main control, drive, and filter boards are all centralized in one control board, making maintenance more convenient.



▶ Automatic address setting

Indoor units IP address can be auto setting during commissioning.

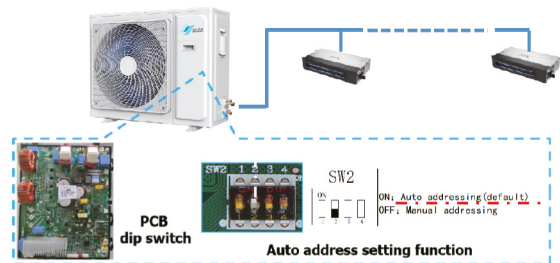

▶ Silent mode

About 3 dB reduce than normal mode, little influence with your neighbors.



* Noise Lab Experiments.

▶ Accurate Temperature Control

According to the change trend of indoor ambient temperature, the unit can use a PI algorithm to calculate the capacity demand percentage of the indoor unit, control the operating frequency of the compressor in real time, and achieve accurate control of room temperature.

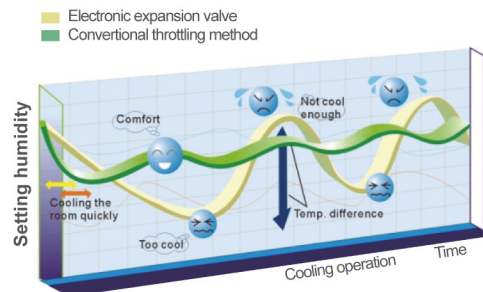

* Performance lab experiment.

MODULAR MANDO MINI

► Large Capacity&Free Combination

4 basic models from 16kW to 22kW.
 Maximum combination: 66kW, top level in industry.
 Less quantity of system, space saving, easy installation and low cost.



► High EER And COP

MODULAR MANDO MINI achieves the industry's top class energy efficiency in cooling and heating by utilizing all DC inverter compressors.

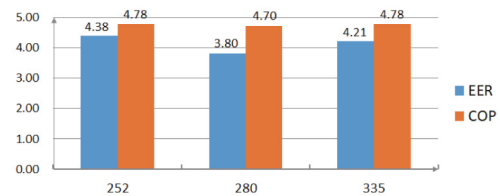

► 180° Sine Wave Control

DC inverter compressor uses 180° sine wave vector control technique makes motor operate smooth and increases the efficiency significantly compared with traditional sawtooth wave. It also can lower the noise level.

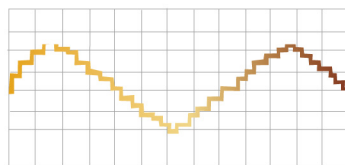

Traditional Control

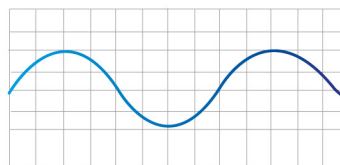

180° Sine Wave DC Control

► High efficiency DC fan motor

DC brushless motor adjusts the fan speed according to the system pressure, and running load to enhance the efficiency by 45%. The super aero fan provides a larger air volume and higher static pressure.



► Module Alternate Operation

In one combination system, any module could run as the master unit according to the running time. Balance the life of the outdoor units in one system.

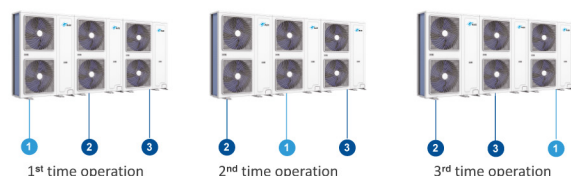

► 2-stage Sub-cooling Technology

Adopting E-pass circuit Reduce resistance and improve heat transfer efficiency.

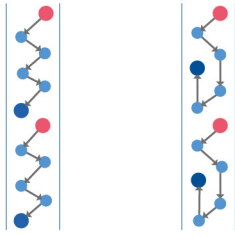

► Seven-levels of limit electricity usage

The unit has the function of energy saving and power limiting (40% - 100% output power limit). Users can choose the automatic energy saving mode. The system optimizes the output based on changes in ambient temperature, improving the comprehensive operating energy efficiency of the unit.



*Data Source: July 13, 2023 MANDO Software Functionality Testing

► Long Piping Length

- Max. Total piping length — 560m
- Max. piping length between ODU and farthest IDU — 150/175m
- Max. piping length from 1st indoor branch to the farthest indoor unit — 40m
- Max. Level difference between indoor units — 30m
- Max. Level difference between ODU and IDU units — 40m/50m



*Data Source: theoretical calculation

► Non-Polar Communication

Non-polar communication between IDUs ,easy installation and commissioning.

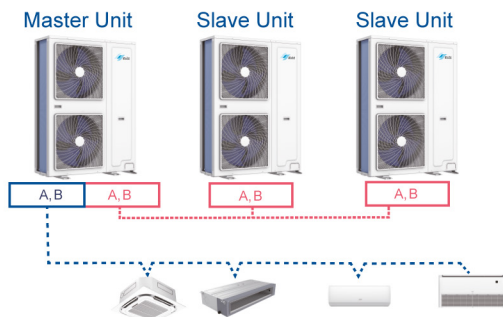

► 12 levels silent modes

"6-levels night silent modes.
6-levels daytime silent modes".

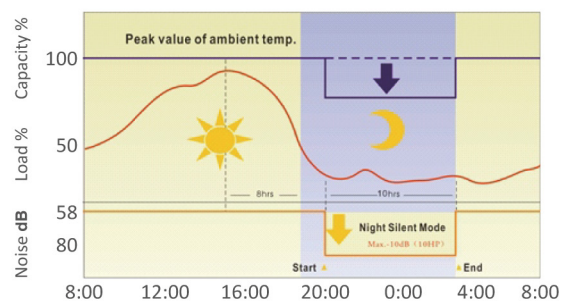

*Data Source: July 13, 2023 Software Functionality Testing

MANDO Mini Series



MANDO MINI 50/60Hz Single-Phase

Model			RFH-AXM-100 WV2	RFH-AXM-120 WV2	RFH-AXM-140 WV2
Code			10KW	12KW	14KW
Power Supply			V~,Hz,Ph	220~240,50/60,1	220~240,50/60,1
Cooling	Capacity	kW	10.2	12.3	14.1
	Capacity (T3)	kW	9.3	11.1	12.6
	Input	kW	2.30	2.80	3.58
	Input (T3)	kW	2.70	3.15	4.25
	EER	WW	4.43	4.39	3.94
	EER (T3)	/	3.44	3.52	2.96
	Rated current	A	10.32	12.56	16.06
	Rated current (T3)	A	12.11	14.13	19.07
Heating	Capacity	kW	11.5	13.2	16.0
	COP	WW	4.04	3.87	4.07
	Input	kW	2.85	3.41	3.93
	Rated current	A	12.75	15.28	17.62
Compressor	Type	/	Rotary	Rotary	Rotary
	Quantity	/	1	1	1
Fan Motor	Type	/	DC Inv	DC Inv	DC Inv
	Quantities	/	2	2	2
Air Flow Volume	CFM		3973	3973	3973
	m3/h		6750	6750	6750
Noise Level		dB(A)	56	56	57
Dimension (W×D×H)	Net	mm	940×340×1320	940×340×1320	940×340×1320
	Packing	mm	1080×430×1440	1080×430×1440	1080×430×1440
Weight	Net	kg	88	88	88
	Gross	kg	98	98	98
Refrigerant type/Quantity	Type	/	R410A	R410A	R410A
Refrigerant Piping	Max. Length	m	150	150	150
	Max. Height	m	50	50	50
Ambient Temperature Range(Cooling/Heating)		°C	-15~54/-20~24	-15~54/-20~24	-15~54/-20~24
Stuffing Quantity	20/40/40H	Unit	27/55/55	27/55/55	27/55/55

MANDO MINI 50/60Hz Three-Phase

Model			RFH-AXM-160 WV2	RFH-AXM-180 WV2	RFH-AXM-200 WV2	RFH-AXM-220 WV2
Code			16kW	18kW	20kW	22kW
Power Supply			V~,Hz,Ph	380~415,50/60,3	380~415,50/60,3	380~415,50/60,3
Cooling	Capacity	kW	16.05	18.0	20.2	22.4
	Capacity (T3)	kW	14.1	16.5	18.0	20.0
	Input	kW	4.70	5.30	5.40	6.10
	Input (T3)	kW	5.40	6.00	6.40	7.00
	EER	WW	3.40	3.40	3.70	3.65
	EER (T3)	/	2.60	2.75	2.80	2.85
	Rated current	A	7.25	8.17	8.20	9.30
	Rated current (T3)	A	8.33	9.25	9.70	10.80
Heating	Capacity	kW	18.0	20.2	22.0	24.2
	COP	WW	3.60	3.38	3.67	3.36
	Input	kW	5.00	5.98	6.00	7.20
	Rated current	A	7.71	9.22	9.20	11.00
Compressor	Type	/	Rotary	Rotary	Rotary	Rotary
	Quantity	/	1	1	1	1
Fan Motor	Type	/	DC Inv	DC Inv	DC Inv	DC Inv
	Quantities	/	2	2	2	2
Air Flow Volume	CFM		9000	9000	9000	9000
	m3/h		15300	15300	15300	15300
Noise Level		dB(A)	43-58	43-58	43-58	43-58
Dimension (W×D×H)	Net	mm	1120×400×1540	1120×400×1540	1120×400×1540	1120×400×1540
	Packing	mm	1270×560×1710	1270×560×1710	1270×560×1710	1270×560×1710
Weight	Net	kg	152	152	152	152
	Gross	kg	162	162	162	162
Refrigerant type/Quantity	Type	/	R410A	R410A	R410A	R410A
Refrigerant Piping	Max. Length	m	560	560	560	560
	Max. Height	m	50	50	50	50
Ambient Temperature Range(Cooling/Heating)		°C	-15~54/-20~24	-15~54/-20~24	-15~54/-20~24	-15~54/-20~24
Stuffing Quantity	20/40/40H	Unit	17/37/37	17/37/37	17/37/37	17/37/37

Notes:

- Cooling Capacity: Indoor temperature 27°C DB/ 19°C WB; Outdoor temperature:35°C DB/ 24°C WB.
- Cooling Capacity (Tropical): Indoor temperature 27°C DB/19°C WB; Outdoor temperature:46.1°C DB.
- Heating Capacity: Indoor temperature 20°C DB; Outdoor temperature: 7°C DB/ 6°C WB.
- Piping Length: Equivalent piping length: 7.5m, level difference: 0m.
- Anechoic chamber conversion value, measured in test room. During actual operation. These values are normally somewhat higher as a result of ambient conditions.
- The above designs and specifications are subject to change without prior notice. Final specifications please refer to technical specification provided by sales representative.



Large Capacity & Free Combination

4 basic models from 16kW to 22kW

Maximum combination: 66kW, top level in industry.

Less quantity of system, space saving, easy installation and low cost.

Indoor Units



Compact Cassette



Cassette Q

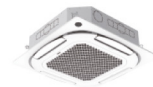

Wall-Mounted J



Wall-Mounted C



Slim Duct

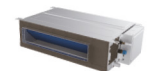

Mid ESP Duct



High ESP Duct



Fresh Air Processing Unit



Ceiling & Floor

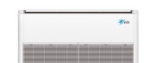

COMPACT CASSETTE



Feature

▶ External control box

External control box, no need to disassemble the unit, convenient maintenance.



▶ Easy to remove wind blades

Thanks to the external design of the electronic control box, the fan blades can be easily removed after removing the air guide ring, making it easy for after-sales maintenance.



▶ Fresh Air Intake

Fresh air makes indoor air healthy and comfortable.



▶ Large air flow

Optimized structure of air guide ring, Insertion depth design of guide ring through simulation technology, Ensure large air flow, improve cooling & heating comfort .

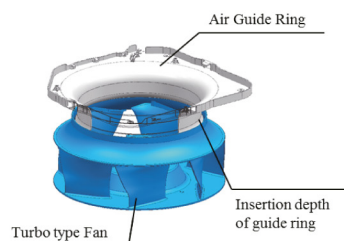

CASSETTE Q



Feature

▶ Digital display board

Capable of displaying temperature, error codes, and operating status, The controller supports setting the temperature to 0.5°C.



*Controlled by XK10 wired controller only

▶ Independent swing air control

Four air blades can be independently controlled to meet personalized air supply needs.



*Controlled by XK10 wired controller only

▶ Slim body

The depth is 205mm only taking up less installation space on the ceiling.

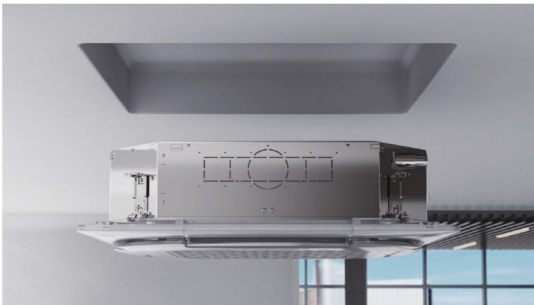

▶ Self-cleaning

Self-cleaning technology and high-temperature treatment help reduce surface pollutant on the evaporator, contributing to cleaner and fresher air.

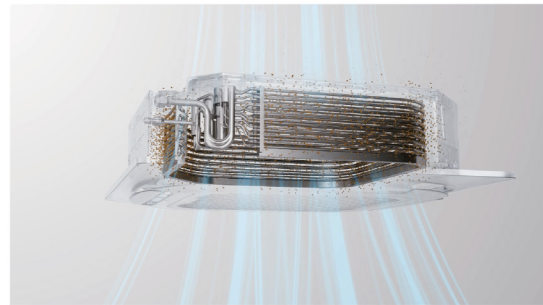

▶ Wifi function(Optional)

Remotely control the air conditioner to achieve temperature adjustment, mode setting, etc., making life more intelligent and convenient.



▶ Easy disassemble

The motor is easy to disassemble, no need to remove the drain pan.

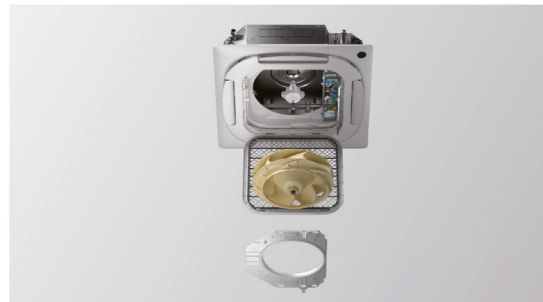

WALL-MOUNTED J

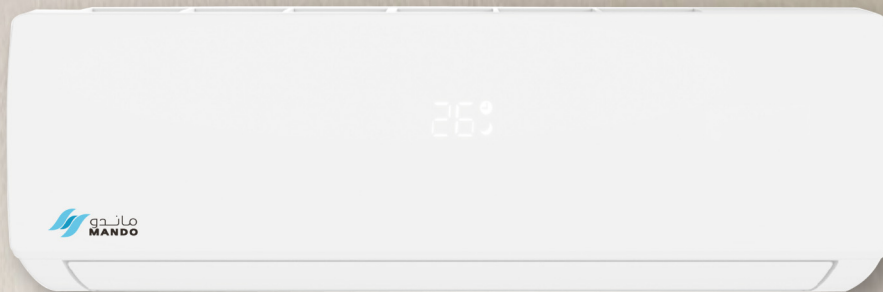

FEATURES

■ optional ■ standard



Remote Control



Intelligent Defrosting



Sleep Mode



Fast Cooling/Heating



Anti-Cold-Air



Digital Tube Display



Wired Control



Central Control



WIFI Control

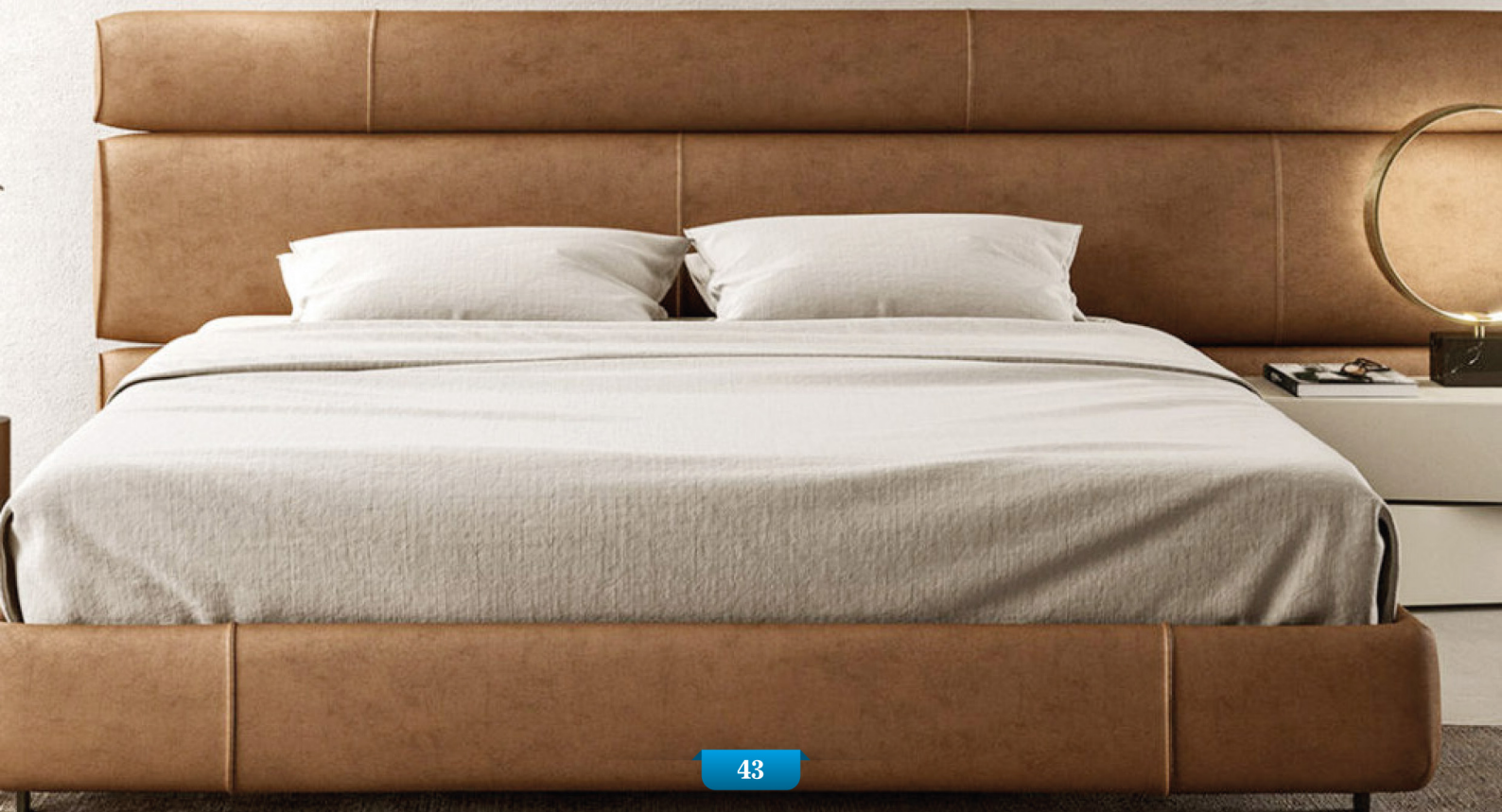

Feature

▶ A Variety Of Panels

A variety of panels can be chosen.

▶ Wired Control

Remote controller is standard, and wired controller is optional. Wired controller can be fixed on the wall to avoid mislaying. It's mainly used for commercial zone and makes air conditioner control more convenient.

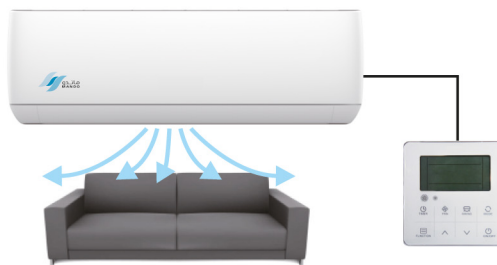

▶ 2 Ways Draining Connection

Both left and right sides of unit are possible for drainage pipe connection, easy for installation.

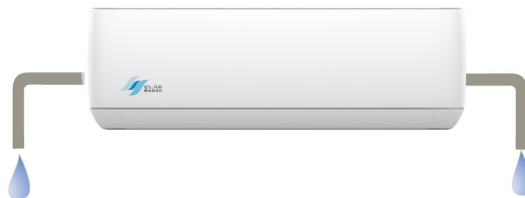

▶ Convenient Installation

EXV is built-in the indoor unit, compact size. Adopts new type fixing plate, stable and easy to install.

▶ Superb craftsmanship

0.3mm seam, appearance integration.

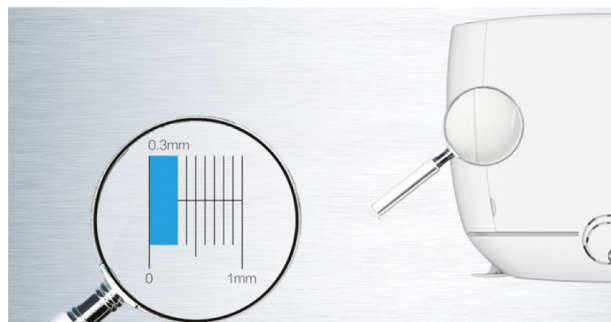

WALL-MOUNTED C



Feature

► Wired Control

Remote controller is standard, and wired controller is optional. Wired controller can be fixed on the wall to avoid mislaying. It's mainly used for commercial zone and makes air conditioner control more convenient.

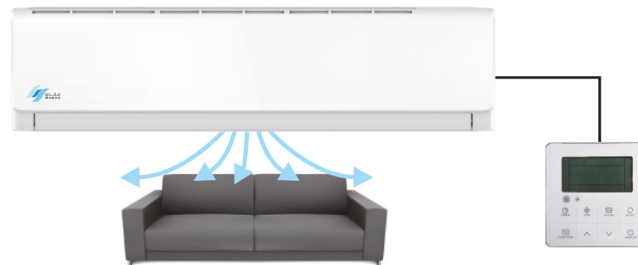

► 2 Ways Draining Connection

Both left and right sides of unit are possible for drainage pipe connection, easy for installation.

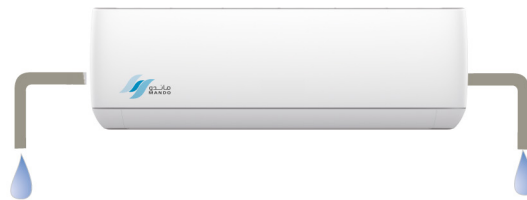

► WIFI Function

Intelligent remote control, convenient operation



► Better experience

MANDO adopt high density filter, good quality , filtering effect and easy to clean.

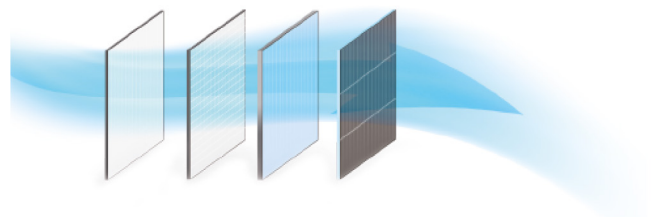

SLIM DUCT (Q Series)



Feature

► Fresh air inlet

Fresh air inlet design, fresh air can be introduced to ensure fresh air in the room.



► Two return air modes are selected

Two return air modes are selected (back return air and bottom return air), and the bottom plate is removed to change the lower return air.

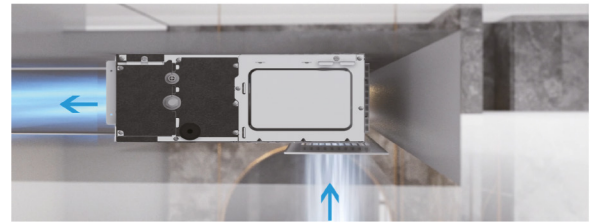
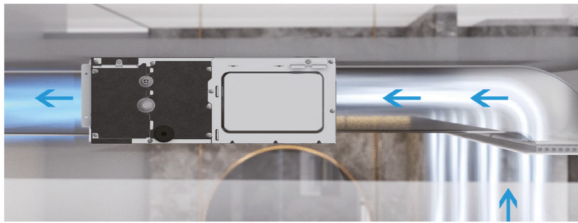

► Design of hanger position

There is a distance between the hanger and the top cover for easy lifting by hand.

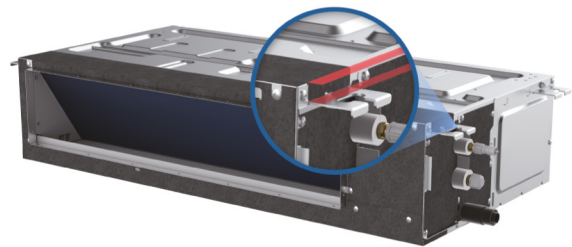

► New structure

Strength analysis through simulation, optimize the structure, improve the strength, not easily deformed during transportation.

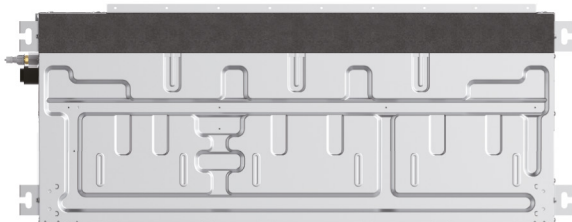

► Electric control box built-in

Built in electronic control box, and the stuffing quantity is greatly increased.

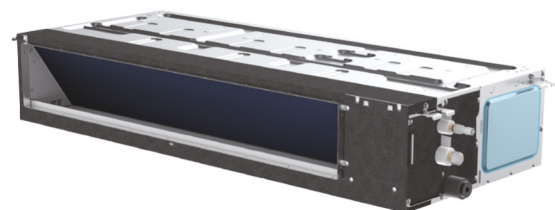

MID ESP DUCT



Feature

► Fresh air inlet

Fresh air inlet design, fresh air can be introduced to ensure fresh air in the room.

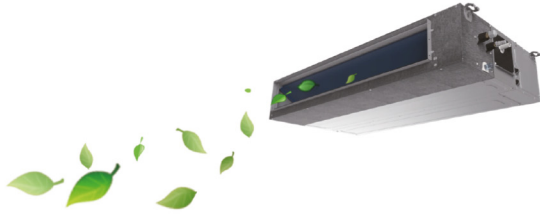

► Silent water pump

Select silent water pump to ensure different customer installation requirements.

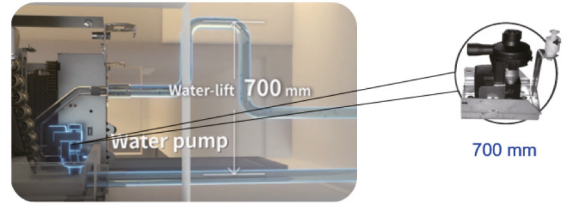

* Data from Zhongbao Laboratory on June 2, 2016.

► Two return air modes are selected

Two return air modes are selected (back return air and down return air), Easy to change.

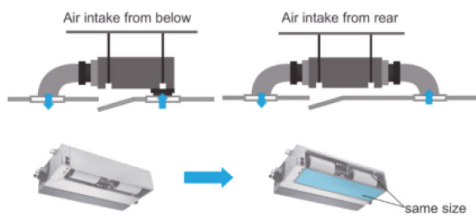

► Constant Air Flow Volume

(only certain model support)

Under different ESP, the product supply Constant air flow volume for comfort.

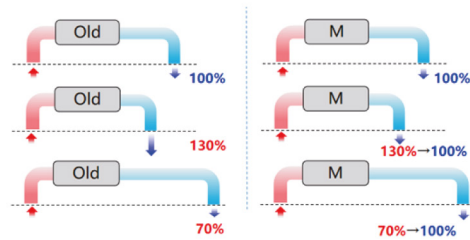

* Performance Lab on July 1, 2022.

► ESP meet kinds application

(Only DC models support)

Widest ESP range (0-150Pa) with possibility to change ESP by controller and meet different kinds application like apartment, villa...



► W Type High efficiency filter screen

Easy disassembly (0 Screws)

Convenient to wash

High efficiency (W type)

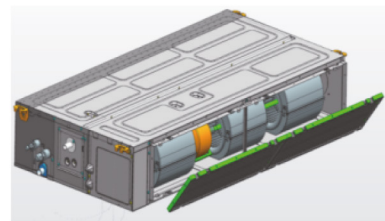

► Electronic control is easy to maintain

Quickly remove 1 screw from the left and right end cover. Change the direction of output line, maintenance without shielding, increase the maintenance space.

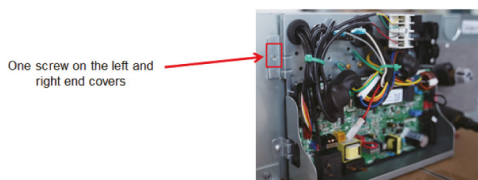

► Double drain holes

Double drainage design on the left and right side of the water plate, flexible to adapt to the installation site.



HIGH ESP DUCT



Feature

► Changeable ESP

Max ESP can up to 250 Pa Wide changeable range (30-250 Pa) , suitable for kinds of application site.

* Data from MANDO Performance Lab on April 22, 2020.

► Multiple wind speed options(Only DC models support)

DC fan motor ,7 fan speed meet customer requirement.



► Double drainage pan

Double drain tray design makes it easier to drain condensate



► Easy to remove air filter

New design (double drainage pan, fan assembly integration), Remove and repair from the bottom, high efficiency.

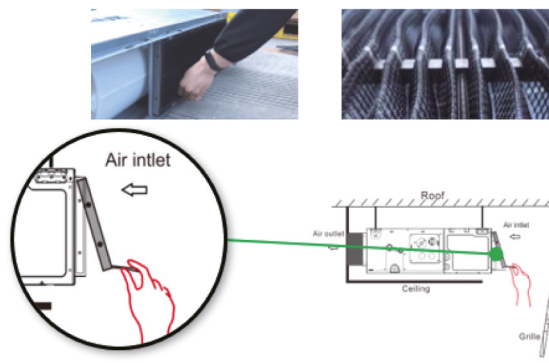

FRESH AIR PROCESSOR



Feature

► Innovative Air Supply Technology For Excellent Room Temperature Control

Fresh air inlet design, fresh air can be introduced to ensure fresh air in the room.

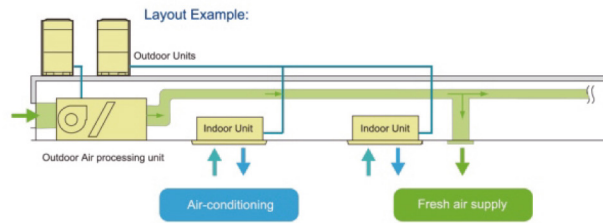

► Long Distance Air Supply

High ESP makes the air supply distance up to 250pa.

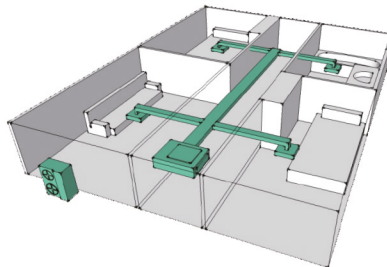

* Data from MANDO Performance Lab on April 22, 2020.

► Applicable To A Variety Of Room Types

Specific ESP design can be applied to various room types easily, like rooms of L type or U type; the air outlet can be set separately from the indoor unit, so the air flow can be equally distributed even the room is in irregular structure.

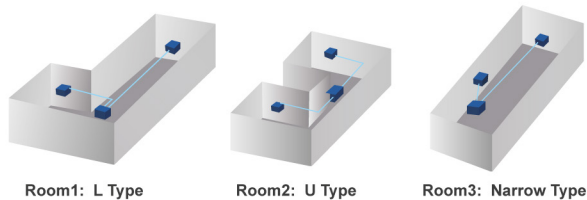

CEILING & FLOOR



Feature

▶ Long Air Supply Distance

Up to 14m, meet large room requirement

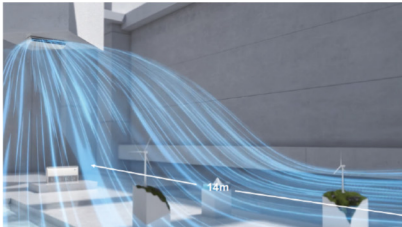

* Data from November 18, 2019 air supply distance laboratory.

▶ Anti-condensation

Industry-leading anti-condensation insulation design of the air outlet

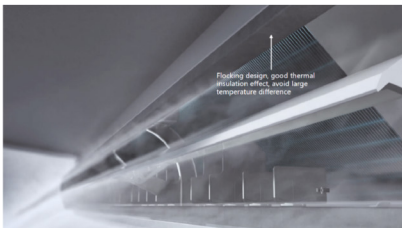

▶ Fresh air intake

Fresh air intake hole design can introduce fresh air to ensure high air quality in the room



▶ Easy drainage

Left and right water outlet design of water connection plate, flexible for installation site



▶ Beautiful Design of Display Board

The display board is beautiful built in design, with good sealing, moisture-proof and long reliable life



▶ Safe and Reliable

Separate design of power and communication terminal to ensure safety

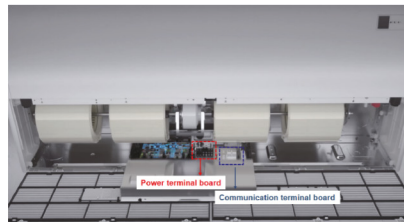

▶ Optional filter

A variety of health filters can be selected to improve room air quality

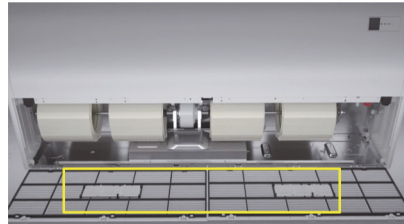

▶ Easy Maintenance

Enough space to maintenance, no need to take out the whole electrical control box

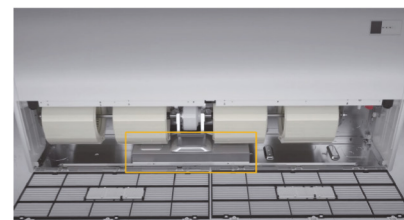

Compact Cassette



Specification-50/60Hz

Model	Indoor		RFCST-4WYCPT-15BB	RFCST-4WYCPT-22BB	RFCST-4WYCPT-28BB	RFCST-4WYCPT-36BB
Capacity	Cooling	kW	1.5	2.2	2.8	3.6
	Heating	kW	1.8	2.5	3.2	4.0
Electric Data	Power Supply	V~,Hz,Ph	220~240,50(60),1	220~240,50(60),1	220~240,50(60),1	220~240,50(60),1
	Rated Power	W	30	30	30	30
Performance	Air Flow Volume(Tu/Hi/Mid/Low)	m3/h	570/530/480/450	570/530/480/450	570/530/480/450	650/620/560/540
	Noise Level(Tu/Hi/Mid/Low)	dB(A)	34/33/32	34/33/32	34/33/32	38/36/35
Dimension (WxDxH)	Net(Body)	mm	570×570×260	570×570×260	570×570×260	570×570×260
	Packing(Body)	mm	720×650×290	720×650×290	720×650×290	720×650×290
	Net(Panel)	mm	650×650×55	650×650×55	650×650×55	650×650×55
	Packing(Panel)	mm	710×710×80	710×710×80	710×710×80	710×710×80
Weight	Net/Gross(Body)	kg	13.5/16.5	13.5/16.5	13.5/16.5	14.5/17.5
	Net/Gross(Panel)	kg	2.2/3.7	2.2/3.7	2.2/3.7	2.2/3.7
Refrigerant Type			R410A	R410A	R410A	R410A
Pipe Diameter	Liquid Side	mm(inch)	6.35	6.35	6.35	6.35
	Gas Side	mm(inch)	9.52	9.52	9.52	12.7
	Drainage	mm(inch)	R3/4in(DN20)	R3/4in(DN20)	R3/4in(DN20)	R3/4in(DN20)
Stuffing Quantity	20/40/40H	unit	216/432/486	216/432/486	216/432/486	216/432/486

Specification-50/60Hz

Model	Indoor		RFCST-4WYCPT-45BB	RFCST-4WYCPT-56BB
Capacity	Cooling	kW	4.5	5.6
	Heating	kW	5.0	6.3
Electric Data	Power Supply	V~,Hz,Ph	220~240,50(60),1	220~240,50(60),1
	Rated Power	W	30	30
Performance	Air Flow Volume(Tu/Hi/Mid/Low)	m3/h	760/740/660/600	800/760/680/620
	Noise Level(Tu/Hi/Mid/Low)	dB(A)	44/41/37	45/42/38
Dimension (WxDxH)	Net(Body)	mm	570×570×260	570×570×260
	Packing(Body)	mm	720×650×290	720×650×290
	Net(Panel)	mm	650×650×55	650×650×55
	Packing(Panel)	mm	710×710×80	710×710×80
Weight	Net/Gross(Body)	kg	15.5/18.5	15.5/18.5
	Net/Gross(Panel)	kg	2.2/3.7	2.2/3.7
Refrigerant Type			R410A	R410A
Pipe Diameter	Liquid Side	mm(inch)	6.35	6.35
	Gas Side	mm(inch)	12.7	12.7
	Drainage	mm(inch)	R3/4in(DN20)	R3/4in(DN20)
Stuffing Quantity	20/40/40H	unit	216/432/486	216/432/486

Notes:

- 1.Cooling Capacity: Indoor temperature 27°C DB/19°C WB; Outdoor temperature:35°C DB/24°C WB.
- 2.Heating Capacity: Indoor temperature 20°C DB; Outdoor temperature:7°C DB/6°C WB.
- 3.Piping Length:Equivalent piping length: 7.5m, l evel difference: 0m.
- 4.Sound level is measured at 1.4m below the unit.
- 5.The above designs and specifications are subject to change without prior notice. Final specifications please refer to technical specification provided by sales representative.

Remarks:

- 1.Data may change according to test surroundings, reserves right of explanation on data.
- 2.All specifications are subject to change by the manufacturer without prior notice.

Cassette Q



Specification-50/60Hz DC fan motor

Model	Indoor		RFCST-4WY-28QB	RFCST-4WY-36QB	RFCST-4WY-45QB	RFCST-4WY-56QB	RFCST-4WY-63QB	RFCST-4WY-71QB
Capacity	Cooling	kW	2.8	3.6	4.5	5.6	6.3	7.1
	Heating	kW	3.2	4.3	5.0	6.3	7.1	8.5
Electric Data	Power Supply	V~,Hz,Ph	220~240,50/60Hz,1	220~240,50/60Hz,1	220~240,50/60Hz,1	220~240,50/60Hz,1	220~240,50/60Hz,1	220~240,50/60Hz,1
	Rated Power	W	40	40	40	40	40	40
Performance	Air Flow Volume(Hi/Mid/Low)	m ³ /h	800/630/550	800/630/550	850/680/580	860/680/580	1150/920/800	1150/920/800
	Noise Level(Hi/Mid/Low)	dB(A)	33/31/30	33/31/30	36/34/33	36/34/33	40/38/36	40/38/36
Dimension (WxDxH)	Net(Body)	mm	840*840*205	840*840*205	840*840*205	840*840*205	840*840*205	840*840*205
	Packing(Body)	mm	915*915*270	915*915*270	915*915*270	915*915*270	915*915*270	915*915*270
	Net(Panel)	mm	950x950x53	950x950x53	950x950x53	950x950x53	950x950x53	950x950x53
	Packing(Panel)	mm	1000x1000x100	1000x1000x100	1000x1000x100	1000x1000x100	1000x1000x100	1000x1000x100
Weight	Net/Gross(Body)	kg	18/22	18/22	18/22	18/22	19/23	19/23
	Net/Gross(Panel)	kg	5.3/7.3	5.3/7.3	5.3/7.3	5.3/7.3	5.3/7.3	5.3/7.3
Refrigerant Type			R32/R410A	R32/R410A	R32/R410A	R32/R410A	R32/R410A	R32/R410A
Pipe Diameter	Liquid Side	mm(inch)	6.35	6.35	6.35	6.35	9.52	9.52
	Gas Side	mm(inch)	12.7	12.7	12.7	12.7	15.88	15.88
	Drainage	mm(inch)	R3/4in(DN20)	R3/4in(DN20)	R3/4in(DN20)	R3/4in(DN20)	R3/4in(DN20)	R3/4in(DN20)
Stuffing Quantity	20/40/40H	unit	108/208/260	108/208/260	108/208/260	108/208/260	108/208/260	108/208/260

Specification-50/60Hz DC fan motor

Model	Indoor		RFCST-4WY-80QB	RFCST-4WY-90QB	RFCST-4WY-100QB	RFCST-4WY-112QB	RFCST-4WY-125QB	RFCST-4WY-140QB	RFCST-4WY-160QB
Capacity	Cooling	kW	8.0	9.0	10.0	11.2	12.5	14.0	16.1
	Heating	kW	9.0	10.0	11.2	13.0	14.0	16.0	18.0
Electric Data	Power Supply	V~,Hz,Ph	220~240,50/60Hz,1	220~240,50/60Hz,1	220~240,50/60Hz,1	220~240,50/60Hz,1	220~240,50/60Hz,1	220~240,50/60Hz,1	220~240,50/60Hz,1
	Rated Power	W	40	80	80	80	80	80	145
Performance	Air Flow Volume(Hi/Mid/Low)	m ³ /h	1150/920/800	1450/1205/960	1450/1205/960	1600/1440/1260	1800/1440/1260	1800/1440/1260	2100/1600/1400
	Noise Level(Hi/Mid/Low)	dB(A)	41/38/36	42/39/36	42/39/36	44/41/38	46/42/39	46/42/39	47/42/37
Dimension (WxDxH)	Net(Body)	mm	840*840*205	840*840*245	840*840*245	840*840*288	840*840*288	840*840*288	840*840*288
	Packing(Body)	mm	915*915*270	915*915*310	915*915*310	915*915*350	915*915*350	915*915*350	915*915*350
	Net(Panel)	mm	950x950x53	950x950x53	950x950x53	950x950x53	950x950x53	950x950x53	950x950x53
	Packing(Panel)	mm	1000x1000x100	1000x1000x100	1000x1000x100	1000x1000x100	1000x1000x100	1000x1000x100	1000x1000x100
Weight	Net/Gross(Body)	kg	19/23	21.5/25	21.5/25	23.5/27.5	23.5/27.5	25/28.5	26.5/30
	Net/Gross(Panel)	kg	5.3/7.3	5.3/7.3	5.3/7.3	5.3/7.3	5.3/7.3	5.3/7.3	5.3/7.3
Refrigerant Type			R32/R410A	R32/R410A	R32/R410A	R32/R410A	R32/R410A	R32/R410A	R32/R410A
Pipe Diameter	Liquid Side	mm(inch)	9.52	9.52	9.52	9.52	9.52	9.52	9.52
	Gas Side	mm(inch)	15.88	15.88	15.88	15.88	15.88	15.88	15.88
	Drainage	mm(inch)	R3/4in(DN20)	R3/4in(DN20)	R3/4in(DN20)	R3/4in(DN20)	R3/4in(DN20)	R3/4in(DN20)	R3/4in(DN20)
Stuffing Quantity	20/40/40H	unit	108/208/260	96/182/234	96/182/234	84/156/208	84/156/208	84/156/208	84/156/208

Notes:

- Cooling Capacity: Indoor temperature 27°C DB/19°C WB; Outdoor temperature: 35°C DB/24°C WB.
- Heating Capacity: Indoor temperature 20°C DB; Outdoor temperature: 7°C DB/6°C WB.
- Piping Length: Equivalent piping length: 7.5m, level difference: 0m.
- Sound level is measured at 1.4m below the unit.
- The above designs and specifications are subject to change without prior notice. Final specifications please refer to technical specification provided by sales representative.

Remarks:

- Data may change according to test surroundings, reserves right of explanation on data.
- All specifications are subject to change by the manufacturer without prior notice.



WALL-MOUNTED J

Specification- 50/60Hz

Model	Indoor		RF-WMT-15J	RF-WMT-22J	RF-WMT-28J	RF-WMT-36J
Capacity	Cooling	kW	1.5	2.2	2.8	3.6
	Heating	kW	1.7	2.6	3.2	4.0
Electric Data	Power Supply	V~,Hz,Ph	220~240,50(60),1	220~240,50(60),1	220~240,50(60),1	220~240,50(60),1
	Rated Power	W	20	20	20	20
Performance	Air Flow Volume(Hi/Mid/Low)	m ³ /h	520/460/400	520/460/400	520/460/400	520/460/400
	Noise Level(Hi/Mid/Low)	dB(A)	38/33/27	38/33/27	38/33/27	38/33/27
Dimension (WxHxD)	Net	mm	881x294x194	881x294x194	881x294x194	881x294x194
	Packing	mm	965x370x282	965x370x282	965x370x282	965x370x282
Weight	Net/Gross	kg	10.5/13	10.5/13	10.5/13	10.5/13
Pipe Diameter	Liquid Side	mm(inch)	6.35(1/4)	6.35(1/4)	6.35(1/4)	6.35(1/4)
	Gas Side	mm(inch)	9.52(3/8)	9.52(3/8)	9.52(3/8)	9.52(3/8)
	Drainage	mm(inch)	R3/4in(DN20)	R3/4in(DN20)	R3/4in(DN20)	R3/4in(DN20)
Stuffing Quantity	20/40/40H	unit	316/647/737	316/647/737	316/647/737	316/647/737

Specification- 50/60Hz

Model	Indoor		RF-WMT-45J	RF-WMT-56J	RF-WMT-71J
Capacity	Cooling	kW	4.5	5.6	7.1
	Heating	kW	5.0	6.3	8.0
Electric Data	Power Supply	V~,Hz,Ph	220~240,50(60),1	220~240,50(60),1	220~240,50(60),1
	Rated Power	W	30	30	40
Performance	Air Flow Volume(Hi/Mid/Low)	m ³ /h	850/750/660	850/750/660	1000/900/800
	Noise Level(Hi/Mid/Low)	dB(A)	42/38/34	42/38/34	44/40/37
Dimension (WxHxD)	Net	mm	997x316x227	997x316x227	1132x330x232
	Packing	mm	1067x385x312	1067x385x312	1205x400x317
Weight	Net/Gross	kg	13.5/16.5	13.5/16.5	15.5/19
Pipe Diameter	Liquid Side	mm(inch)	6.35(1/4)	6.35(1/4)	6.35(1/4)
	Gas Side	mm(inch)	12.7(1/2)	12.7(1/2)	15.88(5/8)
	Drainage	mm(inch)	R3/4in(DN20)	R3/4in(DN20)	R3/4in(DN20)
Stuffing Quantity	20/40/40H	unit	241/498/563	241/498/563	176/410/465

Notes:

- Cooling Capacity: Indoor temperature 27°C DB/19°C WB; Outdoor temperature: 35°C DB/24°C WB.
- Heating Capacity: Indoor temperature 20°C DB; Outdoor temperature: 7°C DB/6°C WB.
- Piping Length: Equivalent piping length: 7.5m, level difference: 0m.
- Sound level is measured 1m below the air outlet horizontally and vertically.
- The above designs and specifications are subject to change without prior notice. Final specifications please refer to technical specification provided by sales representative.

Remarks:

- Data may change according to test surroundings, reserves right of explanation on data.
- All specifications are subject to change by the manufacturer without prior notice.

Wall-Mounted C



Specification 50/60 Hz

Model	Indoor		ARVWM-H022/NR3DCA	ARVWM-H028/NR3DCA	ARVWM-H036/NR3DCA
Capacity	Cooling	kW	2.2	2.8	3.6
	Heating	kW	2.5	3.2	4.0
Electric Data	Power Supply	V~,Hz,Ph	220-240~,50/60Hz,1	220-240~,50/60Hz,1	220-240~,50/60Hz,1
	Rated Power	W	27	27	27
Performance	Air Flow Volume(Hi/Mid/Low)	m ³ /h	545/460/435	545/460/435	545/460/435
	Noise Level(Hi/Mid/Low)	dB(A)	37/34/32	37/34/32	37/34/32
Dimension (WxDxH)	Net	mm	834× 299× 202	834× 299× 202	834× 299× 202
	Packing	mm	891× 371× 282	891× 371× 282	891× 371× 282
Weight	Net/Gross	kg	9.5/11.5	9.5/11.5	9.5/11.5
Refrigerant Type			R410A/R32	R410A/R32	R410A/R32
Pipe Diameter	Liquid Side	mm(inch)	6.35(1/4)	6.35(1/4)	6.35(1/4)
	Gas Side	mm(inch)	9.52(3/8)	9.52(3/8)	9.52(3/8)
	Drainage	mm(inch)	R1/2in(DN16)	R1/2in(DN16)	R1/2in(DN16)
Stuffing Quantity	20/40/40H	unit	318/690/756	318/690/756	318/690/756

Specification 50/60 Hz

Model	Indoor		ARVWM-H045/NR3DCA	ARVWM-H056/NR3DCA	ARVWM-H071/NR3DCA
Capacity	Cooling	kW	4.5	5.6	7.1
	Heating	kW	5.0	6.3	8.0
Electric Data	Power Supply	V~,Hz,Ph	220-240~,50/60Hz,1	220-240~,50/60Hz,1	220-240~,50/60Hz,1
	Rated Power	W	40	40	50
Performance	Air Flow Volume(Hi/Mid/Low)	m ³ /h	815/685/590	815/685/590	1110/990/835
	Noise Level(Hi/Mid/Low)	dB(A)	41/35/30	41/35/30	44/41/37
Dimension (WxDxH)	Net	mm	997× 312× 222	997× 312× 222	1145× 331× 230
	Packing	mm	1070× 385× 327	1070× 385× 327	1210× 400× 327
Weight	Net/Gross	kg	12/15	12/15	14/17.5
Refrigerant Type			R410A/R32	R410A/R32	R410A/R32
Pipe Diameter	Liquid Side	mm(inch)	6.35(1/4)	6.35(1/4)	6.35(1/4)
	Gas Side	mm(inch)	12.7(1/2)	12.7(1/2)	12.7(1/2)
	Drainage	mm(inch)	R1/2in(DN16)	R1/2in(DN16)	R1/2in(DN16)
Stuffing Quantity	20/40/40H	unit	224/475/528	224/475/528	180/387/430

Notes:

- Cooling Capacity: Indoor temperature 27°C DB/19°C WB; Outdoor temperature: 35°C DB/24°C WB.
- Heating Capacity: Indoor temperature 20°C DB; Outdoor temperature: 7°C DB/6°C WB.
- Piping Length: Equivalent piping length: 7.5m, level difference: 0m.
- Sound level is measured 1m below the air outlet horizontally and vertically.
- The above designs and specifications are subject to change without prior notice. Final specifications please refer to technical specification provided by sales representative.

Remarks:

- Data may change according to test surroundings, reserves right of explanation on data.
- All specifications are subject to change by the manufacturer without prior notice.

Wall-Mounted C



Specification 50/60 Hz

Model	Indoor		RF-WMT-80C	RF-WMT-90C
Capacity	Cooling	kW	8	9
	Heating	kW	9	10
Power Supply		V~,Hz,Ph	220~240,50/60,1	220~240,50/60,1
Performance	Air Flow Volume(Hi/Mid/Low)	m3/h	1500/1400/1100/950	1500/1400/1100/950
	Noise Level(Hi/Mid/Low)	dB(A)	48/46/43/40/38	48/46/43/40/38
Dimension (WxDxH)	Net (W×H×D)	mm	1460*375*270	1460*375*270
	Packing (W×H×D)	mm	1555*460*377	1555*460*377
Weight	Net/Gross	kg	23/27	23/27
Pipe Diameter	Liquid Side	mm(inch)	9.52(3/8)	9.52(3/8)
	Gas Side	mm(inch)	15.88(5/8)	15.88(5/8)
	Drainage	mm(inch)	R3/4in(DN20)	R3/4in(DN20)
Stuffing Quantity	20/40/40H	unit	109/232/257	109/232/257

Specification 50/60 Hz

Model	Indoor		RF-WMT-100C	RF-WMT-110C
Capacity	Cooling	kW	10	11
	Heating	kW	11	12.0
Power Supply		V~,Hz,Ph	220~240,50/60,1	220~240,50/60,1
Performance	Air Flow Volume(Hi/Mid/Low)	m3/h	1500/1400/1100/950	1500/1400/1100/950
	Noise Level(Hi/Mid/Low)	dB(A)	48/46/43/40/38	48/46/43/40/38
Dimension (WxDxH)	Net (W×H×D)	mm	1460*375*270	1460*375*270
	Packing (W×H×D)	mm	1555*460*377	1555*460*377
Weight	Net/Gross	kg	23/27	23/27
Pipe Diameter	Liquid Side	mm(inch)	9.52(3/8)	9.52(3/8)
	Gas Side	mm(inch)	15.88(5/8)	15.88(5/8)
	Drainage	mm(inch)	R3/4in(DN20)	R3/4in(DN20)
Stuffing Quantity	20/40/40H	unit	109/232/257	109/232/257

Notes:

- Cooling Capacity: Indoor temperature 27°C DB/19°C WB; Outdoor temperature: 35°C DB/24°C WB.
- Heating Capacity: Indoor temperature 20°C DB; Outdoor temperature: 7°C DB/6°C WB.
- Piping Length: Equivalent piping length: 7.5m, level difference: 0m.
- Sound level is measured 1m below the air outlet horizontally and vertically.
- The above designs and specifications are subject to change without prior notice. Final specifications please refer to technical specification provided by sales representative.

Remarks:

- Data may change according to test surroundings, reserves right of explanation on data.
- All specifications are subject to change by the manufacturer without prior notice.

Slim Duct (Q Series)

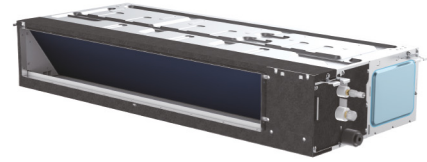

Specification 50/60Hz

Model	Indoor		RFDCT-SL-15T3	RFDCT-SL-22T3	RFDCT-SL-28T3	RFDCT-SL-36T3
Capacity	Cooling	kW	1.5	2.2	2.8	3.6
	Heating	kW	1.8	2.5	3.2	4.0
Electric Data	Power Supply	V~,Hz,Ph	220-240~,50/60Hz,1	220-240~,50/60Hz,1	220-240~,50/60Hz,1	220-240~,50/60Hz,1
	Rated Power	W	31	31	31	31
Performance	Air Flow Volume(Tu/Hi/Mid/Low)m ³ /h		460/400/340	460/400/340	460/400/340	605/500/430
	Noise Level(Hi/Mid/Low)	dB(A)	30/26/22	30/26/22	30/26/22	30/28/24
	External Static Pressure(ESP)	Pa	13(0~50)	13(0~50)	13(0~50)	13(0~50)
Dimension (WxDxH)	Net	mm	550×450×198	550×450×198	550×450×198	700×450×198
	Packing	mm	715×535×255	715×535×255	715×535×255	865×535×255
Weight	Net/Gross	kg	11/13.5	11/13.5	11/13.5	13/16
Pipe Diameter	Liquid Side	mm(inch)	6.35(1/4)	6.35(1/4)	6.35(1/4)	6.35(1/4)
	Gas Side	mm(inch)	9.52(3/8)	9.52(3/8)	9.52(3/8)	12.7(1/2)
	Drainage	mm(inch)	R1in(DN25)	R1in(DN25)	R1in(DN25)	R1in(DN25)
Stuffing Quantity	20/40/40H	unit	306/621/720	306/621/720	306/621/720	243/504/570

Specification 50/60Hz

Model	Indoor		RFDCT-SL-45T3	RFDCT-SL-56T3	RFDCT-SL-71T3
Capacity	Cooling	kW	4.5	5.6	7.1
	Heating	kW	5.0	6.3	8.0
Electric Data	Power Supply	V~,Hz,Ph	220-240~,50/60Hz,1	220-240~,50/60Hz,1	220-240~,50/60Hz,1
	Rated Power	W	31	31	65
Performance	Air Flow Volume(Tu/Hi/Mid/Low)m ³ /h		800/680/550	900/750/600	1145/945/700
	Noise Level(Hi/Mid/Low)	dB(A)	30/26/22	30/26/22	36/32/28
	External Static Pressure(ESP)	Pa	13(0~50)	13(0~50)	13(0~50)
Dimension (WxDxH)	Net	mm	900×450×198	900×450×198	1100×450×198
	Packing	mm	1065×535×255	1065×535×255	1265×535×255
Weight	Net/Gross	kg	15.5/18.5	15.5/18.5	18.5/21.5
Pipe Diameter	Liquid Side	mm(inch)	6.35(1/4)	6.35(1/4)	9.52(3/8)
	Gas Side	mm(inch)	12.7(1/2)	12.7(1/2)	15.88(5/8)
	Drainage	mm(inch)	R1in(DN25)	R1in(DN25)	R1in(DN25)
Stuffing Quantity	20/40/40H	unit	198/396/440	198/396/440	171/360/400

Notes:

1.Cooling Capacity: Indoor temperature 27°C DB/19°C WB; Outdoor temperature:35°C DB/24°C WB.

2.Heating Capacity:Indoor temperature 20°C DB;Outdoor temperature:7°C DB/6°C WB.

3.Piping Length:Equivalent piping length: 7.5m,l evel difference: 0m.

4.Sound level is measured at 1.4m below the unit.

5.The above designs and specifications are subject to change without prior notice. Final specifications please refer to technical specification provided by sales representative.

Remarks:

1.Data may change according to test surroundings, reserves right of explanation on data.

2.All specifications are subject to change by the manufacturer without prior notice.



Mid ESP Duct (M Series)

Specification 50/60HZ

Model	Indoor		RFDCT-MSP-45DM	RFDCT-MSP-56DM	RFDCT-MSP-71DM	RFDCT-MSP-80DM	RFDCT-MSP-90DM
Capacity	Cooling	kW	4.5	5.6	7.1	8.0	9.0
	Heating	kW	5.6	6.3	8.0	9.0	10.0
Electric Data	Power Supply	V~,Hz,Ph	220~240,50/60,1	220~240,50/60,1	220~240,50/60,1	220~240,50/60,1	220~240,50/60,1
	Rated Power	W	110	110	125	125	150
Performance	Air Flow Volume(Tu/Hi/Mid/Low)m ³ /h		1000/920/790/700	1000/920/790/700	1680/1350/1100/950	1680/1350/1100/950	1710/1400/1120/950
	Noise Level(Hi/Mid/Low)	dB(A)	39/37/35	39/37/35	40/38/36	41/39/37	41/39/37
	External Static Pressure(ESP)	Pa	50(0-150)	50(0-150)	50(0-150)	50(0-150)	50(0-150)
Dimension (WxDxH)	Net	mm	1000x700x245	1000x700x245	1000x700x245	1000x700x245	1000x700x245
	Packing	mm	1230*830*300	1230*830*300	1230*830*300	1230*830*300	1230*830*300
Weight	Net/Gross	kg	30/36	30/36	30/36	30/36	32/38
Pipe Diameter	Liquid Side	mm(inch)	9.52	9.52	9.52	9.52	9.52
	Gas Side	mm(inch)	15.88	15.88	15.88	15.88	15.88
	Drainage	mm(inch)	R3/4in(DN20)	R3/4in(DN20)	R3/4in(DN20)	R3/4in(DN20)	R3/4in(DN20)
Stuffing Quantity	20/40/40H	unit	72/151/164	72/151/164	72/151/164	72/151/164	72/151/164

Specification 50/60HZ

Model	Indoor		RFDCT-MSP-100DM	RFDCT-MSP-112DM	RFDCT-MSP-125DM	RFDCT-MSP-140DM	RFDCT-MSP-150DM	RFDCT-MSP-160DM
Capacity	Cooling	kW	10.0	11.2	12.5	14.0	15.0	16.0
	Heating	kW	11.2	12.5	14.0	16.0	17.0	18.0
Electric Data	Power Supply	V~,Hz,Ph	220~240,50/60,1	220~240,50/60,1	220~240,50/60,1	220~240,50/60,1	220~240,50/60,1	220~240,50/60,1
	Rated Power	W	150	230	230	230	250	250
Performance	Air Flow Volume(Tu/Hi/Mid/Low) m ³ /h		1710/1400/1120/950	2300/1900/1600/1400	2300/1900/1600/1400	2300/1900/1600/1400	2400/2000/1700/1500	2300/1900/1600/1400
	Noise Level(Hi/Mid/Low)	dB(A)	42/40/38	44/42/40	44/42/40	44/42/40	45/43/41	44/42/40
	External Static Pressure(ESP)	Pa	50(0-150)	50(0-150)	50(0-150)	50(0-150)	50(0-150)	50(0-150)
Dimension (WxDxH)	Net	mm	1000x700x245	1400x700x245	1400x700x245	1400x700x245	1400x700x245	1400x700x245
	Packing	mm	1230*830*300	1630x830x300	1630x830x300	1630x830x300	1630x830x300	1630x830x300
Weight	Net/Gross	kg	32/38	41/48	41/48	41/48	41/48	41/48
Pipe Diameter	Liquid Side	mm(inch)	9.52	9.52	9.52	9.52	9.52	9.52
	Gas Side	mm(inch)	15.88	15.88	15.88	15.88	15.88	15.88
	Drainage	mm(inch)	R3/4in(DN20)	R3/4in(DN20)	R3/4in(DN20)	R3/4in(DN20)	R3/4in(DN20)	R3/4in(DN20)
Stuffing Quantity	20/40/40H	unit	72/151/164	49/98/112	49/98/112	49/98/112	49/98/112	49/98/112

Notes:

- 1.Cooling Capacity: Indoor temperature 27°C DB/ 19°C WB; Outdoor temperature:35°C DB/ 24°C WB.
- 2.Heating Capacity: Indoor temperature 20°C DB; Outdoor temperature: 7°C DB/ 6°C WB.
- 3.Piping Length: Equivalent piping length: 7.5m, level difference: 0m.
- 4.Sound level is measured at 1.4m below the unit.
- 5.The above designs and specifications are subject to change without prior notice. Final specifications please refer to technical specification provided by sales representative.

Remarks:

- 1.Data may change according to test surroundings, reserves right of explanation on data.
- 2.All specifications are subject to change by the manufacturer without prior notice.

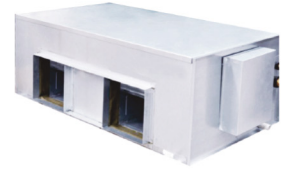

High ESP Duct

Specification 50/60Hz

Model	Indoor		RFDCT-HSP-220DC	RFDCT-HSP-280DC
Capacity	Cooling	kW	22.4	28
	Heating	kW	25	31.5
Electric Data	Power Supply	V~,Hz,Ph	220~240,50/60,1	220~240,50/60,1
	Rated Power	W	1200	1200
Performance	Air Flow Volume	m ³ /h	4400	4400
	Noise Level	dB(A)	57	57
	External Static Pressure(ESP)	Pa	170(30-250)	170(30-250)
Dimension (WxDxH)	Net	mm	1388x715x480	1388x715x480
	Packing	mm	1540x810x610	1540x810x610
Weight	Net/Gross	kg	99/120	99/120
Pipe Diameter	Liquid Side	mm(inch)	12.7(1/2)	12.7(1/2)
	Gas Side	mm(inch)	22.2(7/8)	22.2(7/8)
	Drainage	mm	OD33.5	OD33.5
Stuffing Quantity	20/40/40H	unit	30/63/84	30/63/84

Notes:

- Cooling Capacity: Indoor temperature 27°C DB/19°C WB; Outdoor temperature:35°C DB/ 28°C WB.
- Heating Capacity: Indoor temperature 20°C DB; Outdoor temperature: 7°C DB/ 6°C WB.
- Piping Length: Equivalent piping length: 7.5m, l evel difference: 0m.
- Sound level is measured at 1.4m below the unit.
- The above designs and specifications are subject to change without prior notice. Final specifications please refer to technical specification provided by sales representative.

Remarks:

- Data may change according to test surroundings, reserves right of explanation on data.
- All specifications are subject to change by the manufacturer without prior notice.

Fresh Air Processor



Specification-50/60Hz

Model	Indoor		RFDCT-FA-220DC	RFDCT-FA-280DC
Capacity	Cooling	kW	22.4	28.0
	Heating	kW	18.0	22.0
Electric Data	Power Supply	V~,Hz,Ph	220~240,50/60,1	220~240,50/60,1
	Rated Power	W	900	900
	Air Flow Volume	m ³ /h	3200	3200
Performance	Noise Level	dB(A)	55	55
	External Static Pressure(ESP)	Pa	220	220
Dimension (WxDxH)	Net	mm	1388×715×480	1388×715×480
	Packing	mm	1540×810×610	1540×810×610
Weight	Net/Gross	kg	99/120	99/120
	Liquid Side	mm(inch)	12.7(1/2)	12.7(1/2)
Pipe Diameter	Gas Side	mm(inch)	22.2(7/8)	22.2(7/8)
	Drainage	mm	OD33.5	OD33.5
Stuffing Quantity	20/40/40H	unit	30/63/84	30/63/84

Notes:

- 1.Cooling Capacity: Outdoor temperature 35°C DB/28°C WB.
- 2.Heating Capacity: Outdoor temperature 7°C DB/6°C WB.
- 3.Piping Length: Equivalent piping length: 7.5m, level difference: 0m.
- 4.Sound level is measured at 1.4m below the unit.
- 5.The above design and specifications are subject to change without prior notice. Final specifications please refer to technical specification provided by sales representative.

Connection Conditions:

When only outdoor-air processing units are connected, the total capacity of the outdoor-air processing units must be within 50%~100% of the outdoor units.
When outdoor-air processing units and other type indoor units are connected, the total capacity of the outdoor-air processing units must not exceed 30% of the outdoor units.

Remarks:

- 1.Data may change according to test surroundings, reserves right of explanation on data.
- 2.All specifications are subject to change by the manufacturer without prior notice.

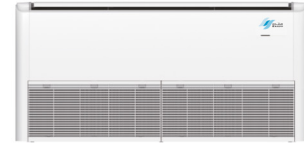

Ceiling & Floor

Specification 50/60Hz

Model	Indoor		RF-CFLR-28DF	RF-CFLR-36DF	RF-CFLR-45DF	RF-CFLR-56DF	RF-CFLR-71DF
Capacity	Cooling	kW	2.8	3.6	4.5	5.6	7.1
	Heating	kW	3.2	4.3	5.0	6.3	8.0
Electric Data	Power Supply	V~,Hz,Ph	220-240V,50/60,1	220-240V,50/60,1	220-240V,50/60,1	220-240V,50/60,1	220-240V,50/60,1
	Rated Power	W	40	40	40	40	40
Performance	Air Flow Volume (Tu/Hi/Mid/Low/SI)	m ³ /h	940/895/700/650/600	940/895/700/650	940/895/700/650/600	940/895/700/650/600	940/895/700/650/600
	Noise Level(Tu/Hi/Mi/Lo/SI)	dB(A)	42/41/38/36	42/41/38/36	42/41/38/37/36	42/41/38/37/36	42/41/38/37/36
Dimension (W×D×H)	Net	mm	1000×690×235	1000×690×235	1000×690×235	1000×690×235	1000×690×235
	Packing	mm	1080×770×325	1080×770×325	1080×770×325	1080×770×325	1080×770×325
Weight	Net	kg	29/33.5	29/33.5	29/33.5	29/33.5	29/33.5
	Liquid Side	mm(inch)	6.35(1/4)	6.35(1/4)	6.35(1/4)	6.35(1/4)	6.35(1/4)
Pipe Diameter	Gas Side	mm(inch)	12.7(1/2)	12.7(1/2)	12.7(1/2)	12.7(1/2)	12.7(1/2)
	Drainage	mm(inch)	R3/4in(DN20)	R3/4in(DN20)	R3/4in(DN20)	R3/4in(DN20)	R3/4in(DN20)
Stuffing Quantity	20/40/40H	unit	112/224/264	112/224/264	112/224/264	112/224/264	112/224/264

Specification 50/60Hz

Model	Indoor		RF-CFLR-80DF	RF-CFLR-90DF	RF-CFLR-112DF	RF-CFLR-125DF	RF-CFLR-140DF
Capacity	Cooling	kW	8.0	9.0	11.2	12.5	14.0
	Heating	kW	9.0	11.0	12.8	14.0	15.0
Electric Data	Power Supply	V~,Hz,Ph	220-240V,50/60,1	220-240V,50/60,1	220-240V,50/60,1	220-240V,50/60,1	220-240V,50/60,1
	Cooling/Heating Power Input	W	70	70	120	120	120
Performance	Air Flow Volume (Tu/Hi/Mid/Low/SI)	m ³ /h	1300/1245/1020/930/840	1300/1245/1020/930/840	2040/1890/1740/1560/1440	2040/1890/1740/1560/1440	2040/1890/1740/1560/1440
	Noise Level(Tu/Hi/Mi/Lo/SI)	dB(A)	43/42/39/38/37	43/42/39/38/37	50/49/45/43/41	50/49/45/43/41	50/49/45/43/41
Dimension (W×D×H)	Net	mm	1280×690×235	1280×690×235	1600×690×235	1600×690×235	1600×690×235
	Packing	mm	1360×770×325	1360×770×325	1680×770×325	1680×770×325	1680×770×325
Weight	Net/Gross	kg	35.5/41	35.5/41	42/49	42/49	42/49
	Liquid Side	mm(inch)	9.52(3/8)	9.52(3/8)	9.52(3/8)	9.52(3/8)	9.52(3/8)
Pipe Diameter	Gas Side	mm(inch)	15.88(5/8)	15.88(5/8)	15.88(5/8)	15.88(5/8)	15.88(5/8)
	Drainage	mm(inch)	R3/4in(DN20)	R3/4in(DN20)	R3/4in(DN20)	R3/4in(DN20)	R3/4in(DN20)
Stuffing Quantity	20/40/40H	unit	84/175/200	84/175/200	70/147/168	70/147/168	70/147/168

Notes:

- 1.Cooling Capacity: Indoor temperature 27°C DB/19°C WB; Outdoor temperature:35°C DB/24°C WB.
- 2.Heating Capacity:Indoor temperature 20°C DB;Outdoor temperature:7°C DB/6°C WB.
- 3.Piping Length:Equivalent piping length: 7.5m, level difference: 0m.
- 4.Floor standing:Sound level is measured 1m from air-outlet in horizontal distance, 1m above the floor in vertical distance.
- 5.Ceiling mounted: Sound level is measured 1m from air-outlet in horizontal distance,1m from air-outlet in vertical distance.
- 6.The above designs and specifications are subject to change without prior notice. Final specifications please refer to technical specification provided by sales representative.

Remarks:

- 1.Data may change according to test surroundings, reserves right of explanation on data.
- 2.All specifications are subject to change by the manufacturer without prior notice.

Remote Controller

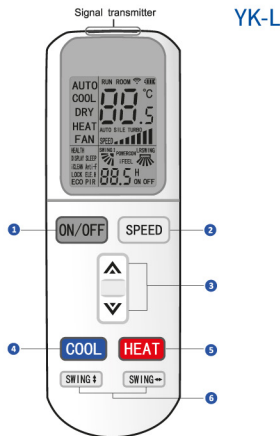

YK-L

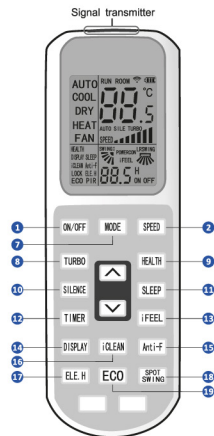

- 1 ON/OFF
- 2 Fan Speed Setting HIGH/MED/LOW/AUTO
- 3 Temperature-Setting /Timer Range Setting
- 4 Cooling Mode
- 5 Heating Mode
- 6 Vertical Swing/Horizontal Swing
- 7 Mode Setting AUTO/COOL/DRY/HEAT/FAN
- 8 Turbo Wind
- 9 Health Function
- 10 Silence Function
- 11 Sleep Function
- 12 Timer On/Off
- 13 I Feel Function
- 14 LED Display On/Off
- 15 Anti-fungus Function
- 16 Clean Function
- 17 Auxiliary Electric Heating
- 18 Spot Swing
- 19 Economic Function

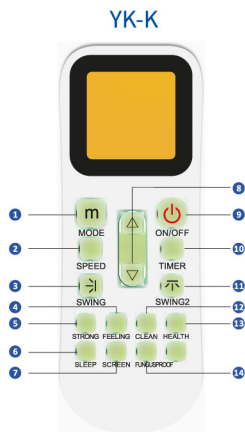

YK-K

- 1 Mode Setting AUTO/COOL/DRY/HEAT/FAN
- 2 Fan Speed Setting HIGH/MED/LOW/AUTO
- 3 Vertical Swing
- 4 Feeling Function
- 5 Strong Wind
- 6 Sleep Function
- 7 LED Display On/Off
- 8 Temperature-Setting /Timer Range Setting
- 9 ON/OFF
- 10 Timer On/Off
- 11 Horizontal Swing
- 12 Clean Function
- 13 Health Function
- 14 Fungusproof Function

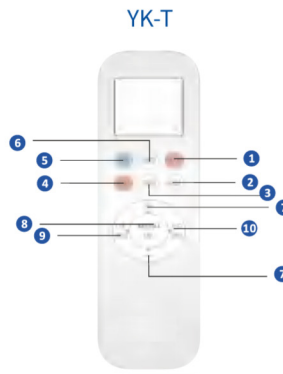

YK-T

- 1 ON/OFF
- 2 Mode Setting AUTO/ COOL/ DRY/ HEAT/ FAN
- 3 Time On/Off
- 4 Heating Mode
- 5 Cooling Mode
- 6 Fan Speed Setting Low/Mid/High/Turbo/Auto
- 7 Temperature-Setting /Timer Range Setting
- 8 MENU & OK Button
- 9 L/R SWING Button
- 10 U/D SWING Button

Function

1. Background light

The background light allows users to operate the device in a dark room. The device lights up when a button is pressed, and turns off when a given operation is completed.

2. Addresses setting

Besides the machine's auto addressing function, users can set the indoor unit's address on the remote controller YK-L.

Specifications

Model	YK-L	YK-K
Dimension (WxHxD) (mm)	52x160x25(max)	50x140x28.5(max)
Power(V)	3V(1.5V×2)	3V(1.5V×2)

Wired Controller



XK-05A

► Function

Built-In Remote Signal Receiver

A signal receiver is built-in the remote controller. Signal from remote controller can be received by wired controller, so the system status could be adjusted using a remote controller.

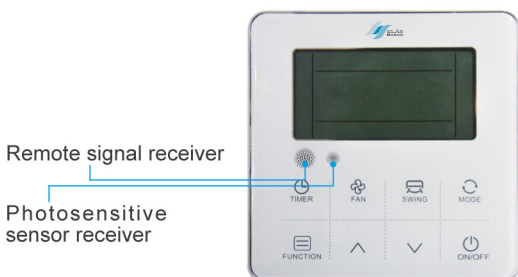

Addresses Setting

The address setting function is coupled with easy installation and simple future maintenance. Service personnel can set the address for the indoor unit using XK-05A.



► Follow Me

With the follow me function, the indoor unit responds to the temperature measured by the temperature sensor built-in the wired controller, rather than temperature sensor in the indoor unit itself, so the temperature is measured closer to the user, rather than at the ceiling or floor height.



► Built-in Timer

The built-in daily timer allows the systems automatically start and stop according to user-defined time setting.



Indoor unit set to stop in 0.5 hours.

► User-Friendly & Elegant Design

The XK-05A is a hidden-mode controller specially designed for hotels, hospitals, schools, offices. Fitted with a background light as standard, easy to use in the dark night.

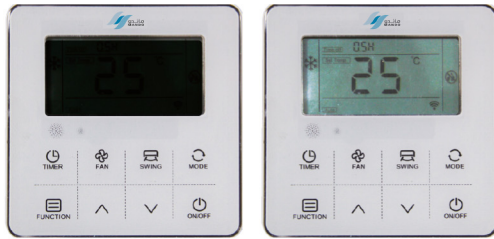

► Error Reporting

If there is a malfunction, error codes are displayed in the temperature setting area of the controller's display screen.

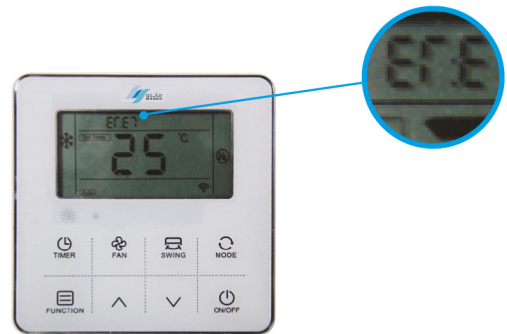

► Keyboard Locking

The locking function could prevent other people changing the setting state at will in public places.

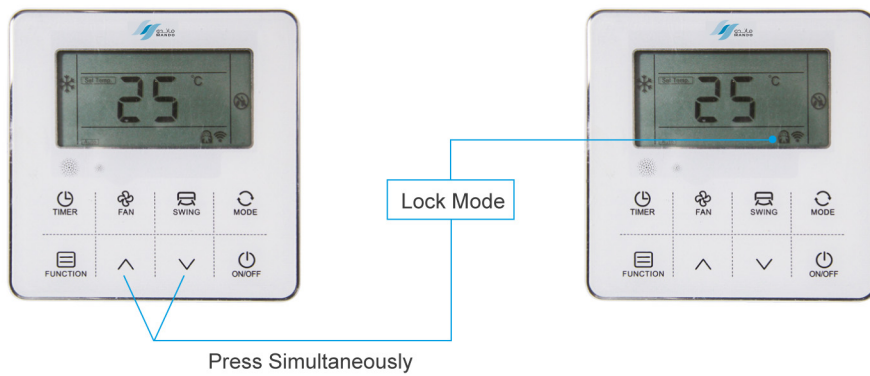

► Features

Specifications

Model	XK-05A 
Dimension (WxHxD) (mm)	120×120×18
Power Supply(V)	DC 12V by IDU



XK-06A

► **New Features**

Weekly timer function

Easy setting of weekly running status

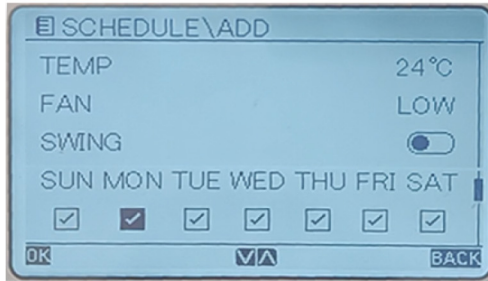

Display room temp (Optional)

Accurately display room temperature

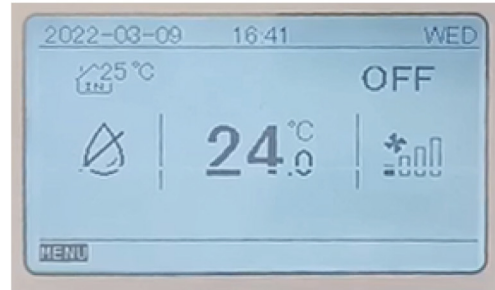

Parameter Setting

Simple and convenient setting of parameter

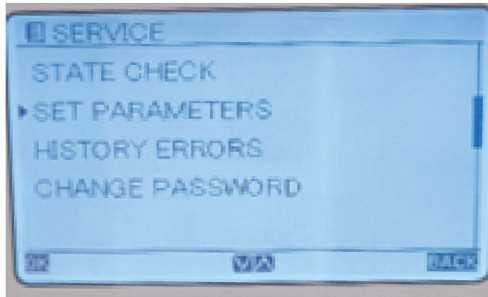

History errors

Simple and quick search of history errors

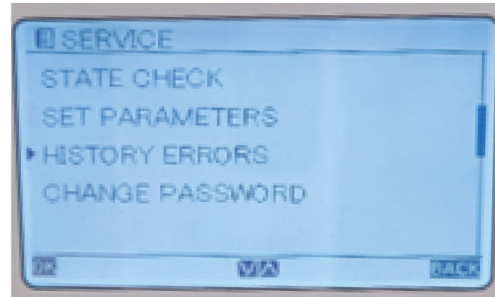

► **Features**

Specifications

Model	XK-06A 
Dimension (WxHxD) (mm)	120×120×20
Power Supply(V)	DC 12V by IDU



XK-10

► New Features

New wired controller

Optional XK-10 wired controller, beautiful appearance, larger screen display

Smaller size

Cooperate with the switch position to enhance the aesthetic appeal of the decoration

5 operating modes Minimum unit: 0.1 °C

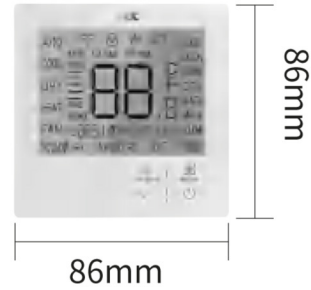

Individual louver control

Four air louver can be adjusted separately, each can choose 5 angles, for cassette Q, a total of 625 Angle combinations

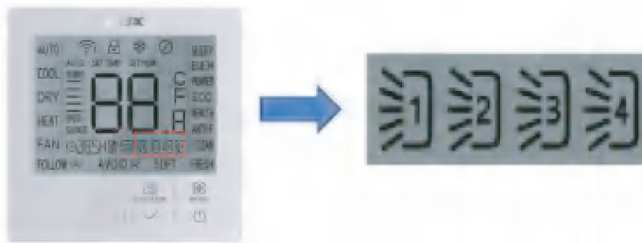

► Features

Specifications

Model	XK-10 
Dimension (WxHxD) (mm)	86 X 86
Power Supply(V)	DC 12V by IDU

Centralized Controllers

► Touch Screen Centralized Control

The MANDO touch screen centralized controller is a multi-functional device that can control up to 256 indoor units within a maximum connection length of 1000 meters.



* Performance Lab on May 8, 2024.

► Multi-system Control

256 indoor units with no repeated address from different outdoor systems could be centralized controlled together. this greatly reduces system limitations.

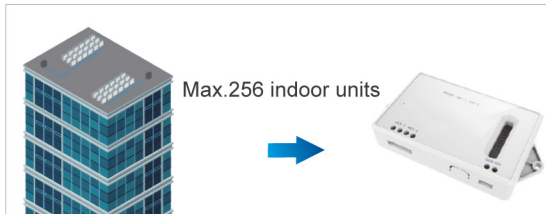

► Multiple Lock function

The new centralized controller could not only lock their own keyboards, it could also enable the users lock each unit's setting mode or remote controller.



► Weekly Schedule Control

The CC-02 centralized controller's weekly schedule timer function allows users to set up to four scheduled periods per day ,each with its own operation mode and temperature setting.

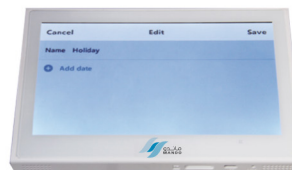

► Indoor Units Operation Status Display

Error and protection codes are shown directly on centralized controller's displays, no need to access outdoor unit's PCBs to obtain codes .The building management professionals could inquire a wide range of historical error and protection codes to get the system status information before contacting a service engineer.



▶ Central controller & connection(produced before 2023.6.30)

The centralized controllers could be connected directly to the master outdoor unit or any indoor unit of each system .so it significantly simply wiring configuration.

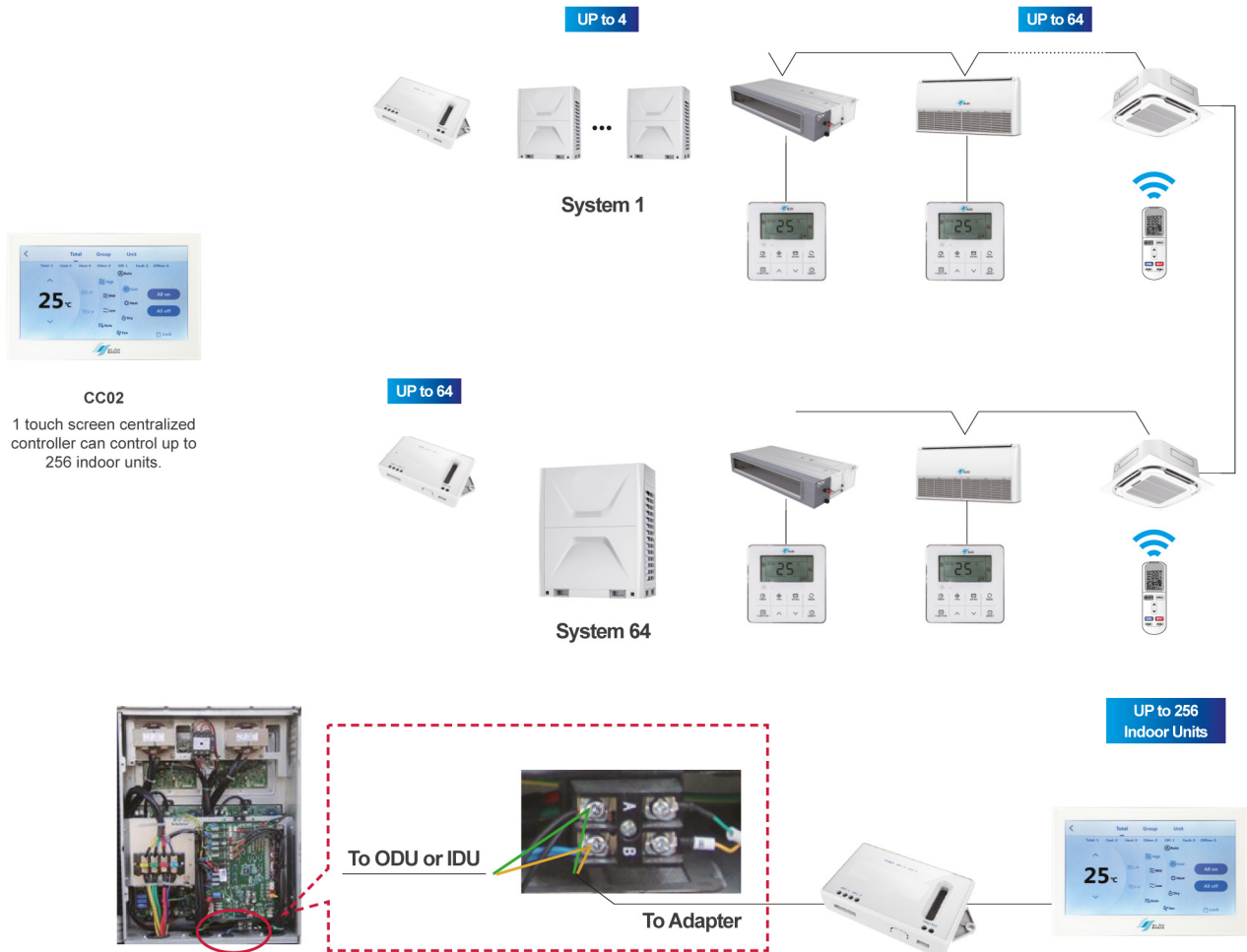

Main Components of Centralized Controller

Model	CC-02	CM-MTD/AM01
Dimension(W×H×D) (mm)	176x116x12 (Outside the wall) 120x60x25 (Inside the wall)	127 ×65.8×20.8mm
Power supply	AC 180-240V (50/60Hz)	DC 12V

► Central controller & connection (produced after 2023.6.30)

Meet different air solution for kinds of application sites.

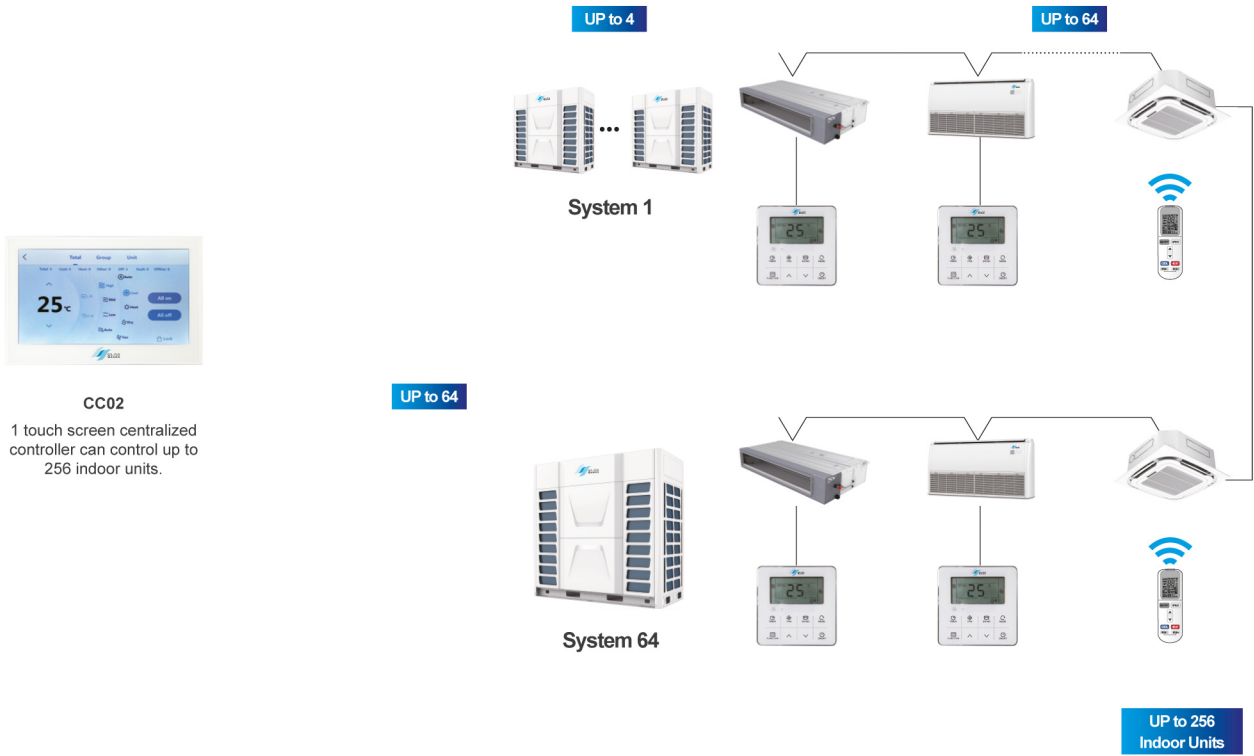

CC02

1 touch screen centralized controller can control up to 256 indoor units.

MANDO M7



To system 1,2...

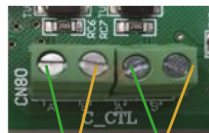

Notes:

It needs to set C9 and C10 parameters. For details, please contact MANDO technical engineers

Centralized Control Software

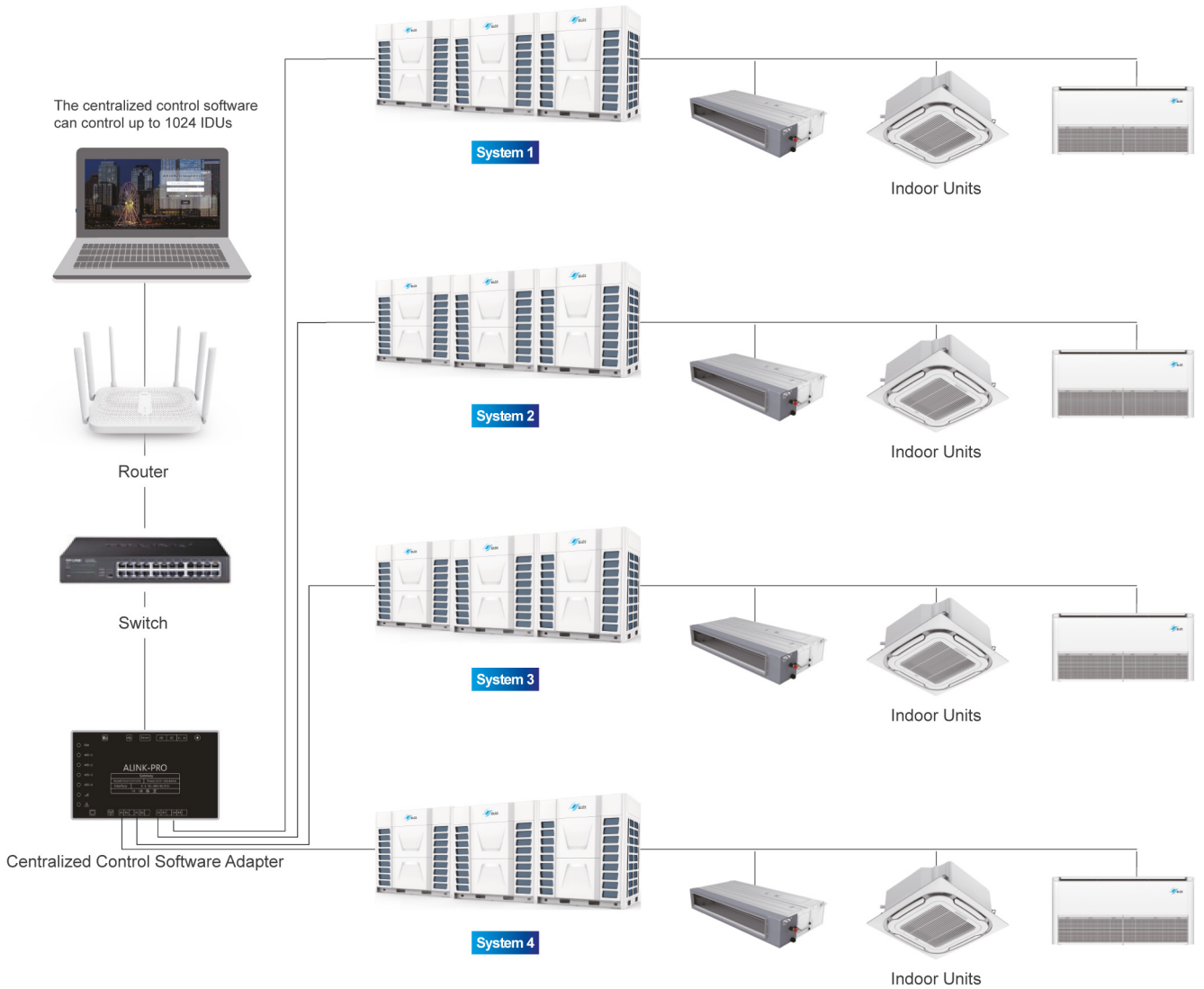

► System Overview



► System Overview

Users do not need to go to the harsh environment of the site, they can monitor the function of units just through computer. This greatly improves convenience of daily management and the efficiency of central air conditioners; Timely find the fault and save the maintenance cost of air conditioner units, minimize losses ; Timer function with multi-period week, fully automated schedule planning of unit;

► Main Components Of Centralized Control System

No	Main Components	Requirement & Function
1	<p>Adapter/Gateway</p> 	<ol style="list-style-type: none"> 1. Model: CM-PTD/A02 2. Power: DC 9~24V,400mA 3. Communication:RS485 4. LAN (DHCP to obtain IP automatically) 4. Baud rate: 9600, 5. "even parity" by number of systems 6. Working condition: -25 C ~55 C , 45%~75% 7.Dimension:178mm×115mm×85mm
2	<p>Centralized control software</p> 	<p>MANDO intelligent management system</p>

Notes:

Routers, switches and other equipments are purchased locally by the user

► Software Introduction Main Interface

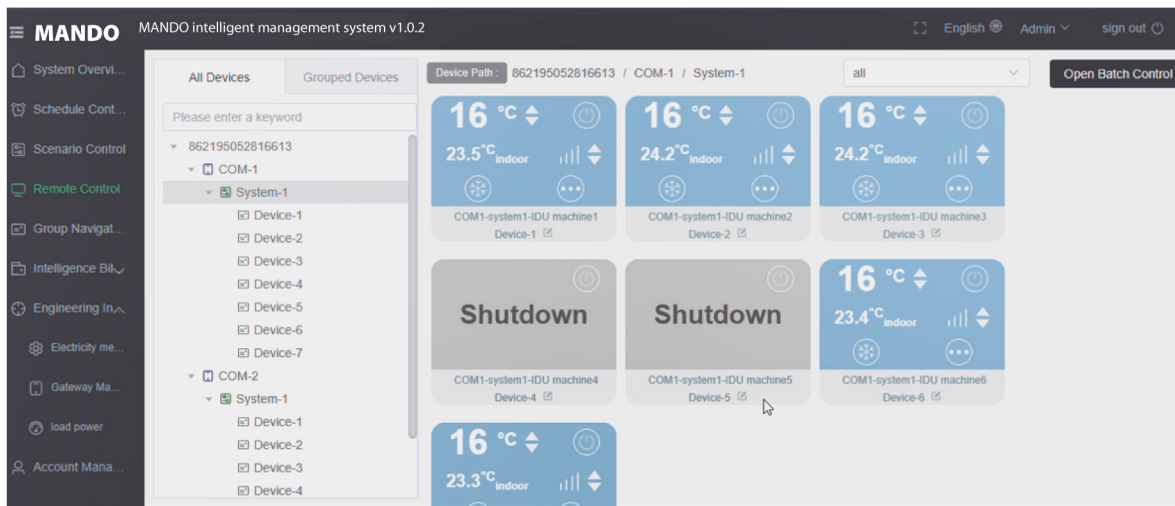
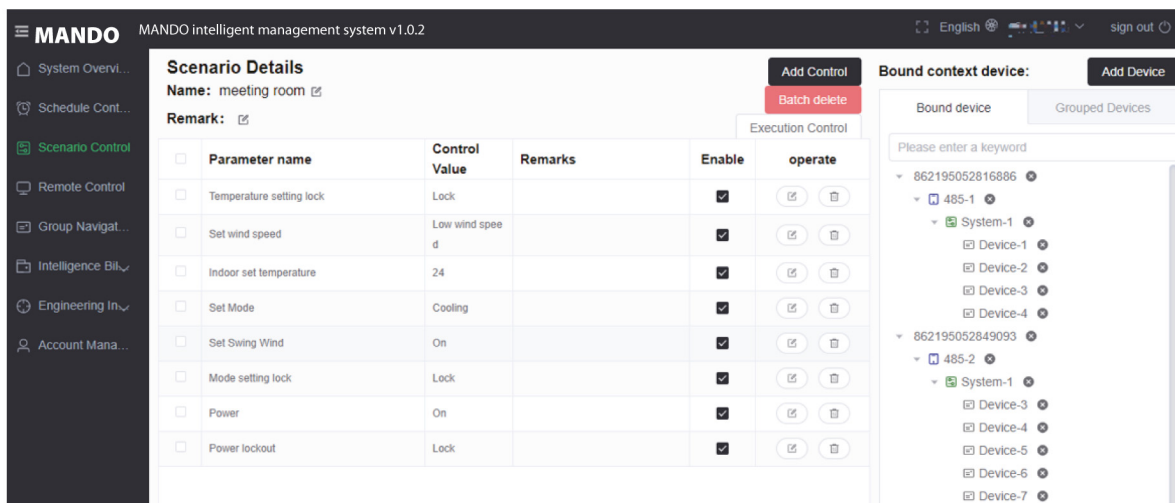
Tenant Billing Solution



► System Overview

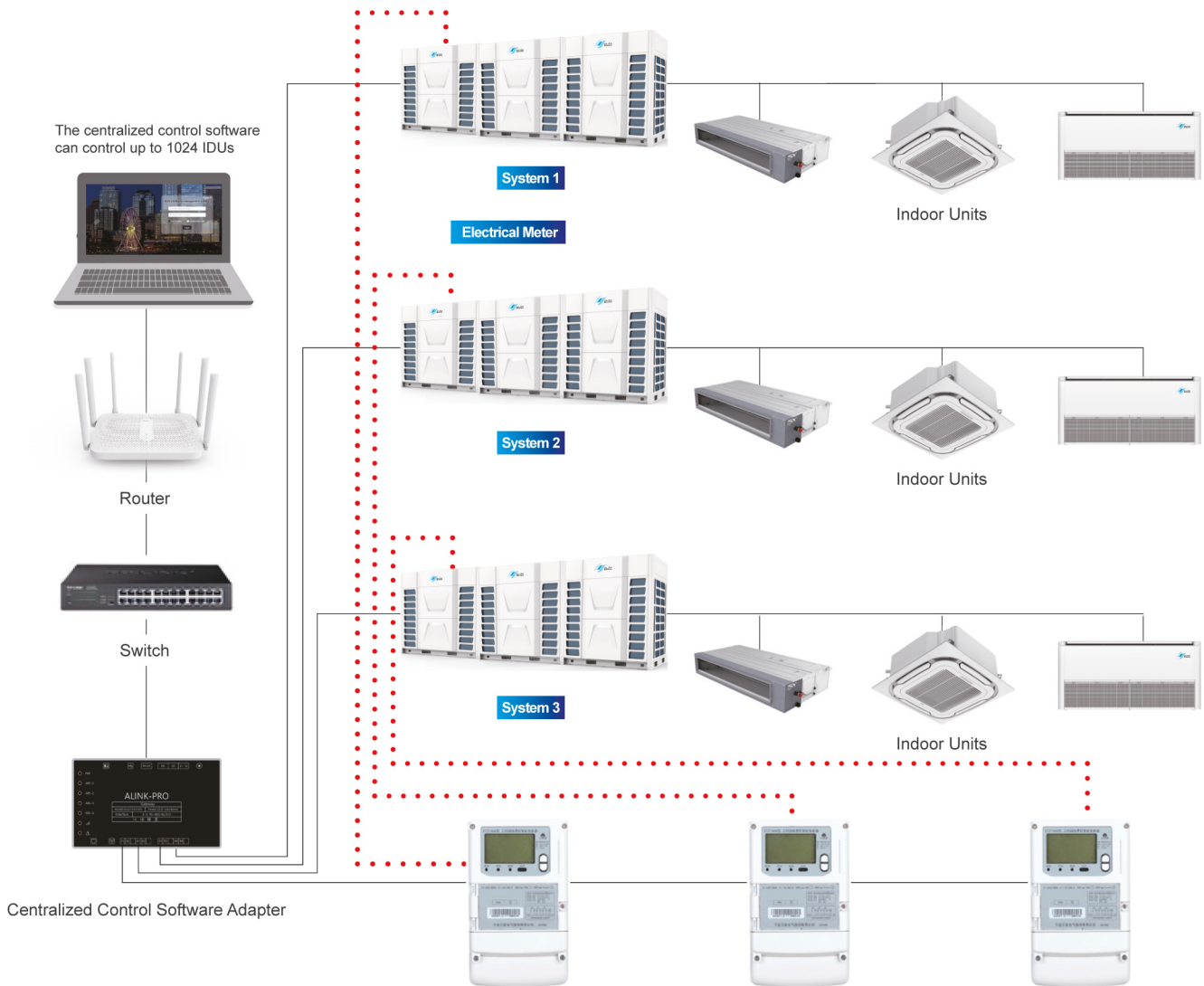

► System Overview

A function that proportionally distributes the total power used by the air conditioners in a rental building, measured by using an electricity meter among the tenants. This function is very suitable for MANDO M7 System.

► Main Components Of Centralized Control System

No	Main Components	Requirement & Function
1	<p>Adapter/Gateway</p> 	<ol style="list-style-type: none"> 1. Model: CM-PTD/A02 2. Power: DC 9~24V,400mA 3. Communication:RS485 4. LAN (DHCP to obtain IP automatically) 4. Baud rate:9600, 5. "even parity" by number of systems 6. Working condition: -25 C ~55 C , 45%~75% 7.Dimension:178mm×115mm×85mm
2	<p>Electrical Meter</p> 	<ol style="list-style-type: none"> 1. Model: DTZY188 2. Voltage: 380V~3ph , 3. Max current : 100A 4. Communication type:RS485 5. Protocol:DL/T 645-2007; 6. Baud rate:9600, parity type : "even parity" 7. Operation: Temp(-25~55 C),humid(45~75%) 8. Dimention: 290×170×85mm
3	<p>Centralized control software</p> 	MANDO intelligent management system

Notes:

Routers, switches and other equipments are purchased locally by the user

► Software Introduction Main Interface

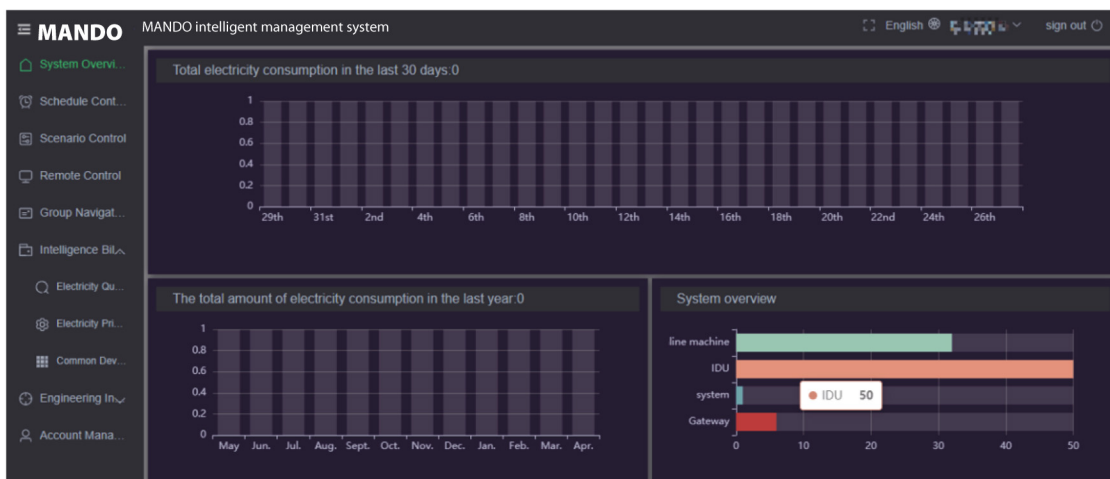

prepaid account	user contact	user name	Number of IDU	Total power (kWh)	Tr Operation
liujia			5	0.00	0 Use Record Export
lushiyong			7	0.00	0 Use Record Export
lshgen					

MANDO Intelligent Management System Air Conditioning Bill								
prepaid account	user contact	user name	report cycle	print date	print date	print date	print date	
liujia	145316	145316	2022-05-24 14:53:16	2022-05-25 14:53:16	2022-05-25 14:53:16	2022-05-25 14:53:16	2022-05-25 14:53:16	
IDU number	Running power	Running electricity bill	ODU running power	ODU electricity bill	Electricity in the public area	Public area electricity bill	Total power (kWh)	Total cost (yuan)
1	0	0	0.24	0.24	0	0	0.24	0.24
2	0	0	0.2	0.2	0	0	0.2	0.2
3	0	0	0.22	0.22	0	0	0.22	0.22
4	0	0	0.57	0.57	0	0	0.57	0.57
5	0	0	0.24	0.24	0	0	0.24	0.24
6	0	0	0.15	0.15	0	0	0.15	0.15
Total electricity consumption (kWh)			6					
Total cost (yuan)			6					
print date			2022-05-25 14:53:24					

BMS System

► Overall Structure

MODBUS

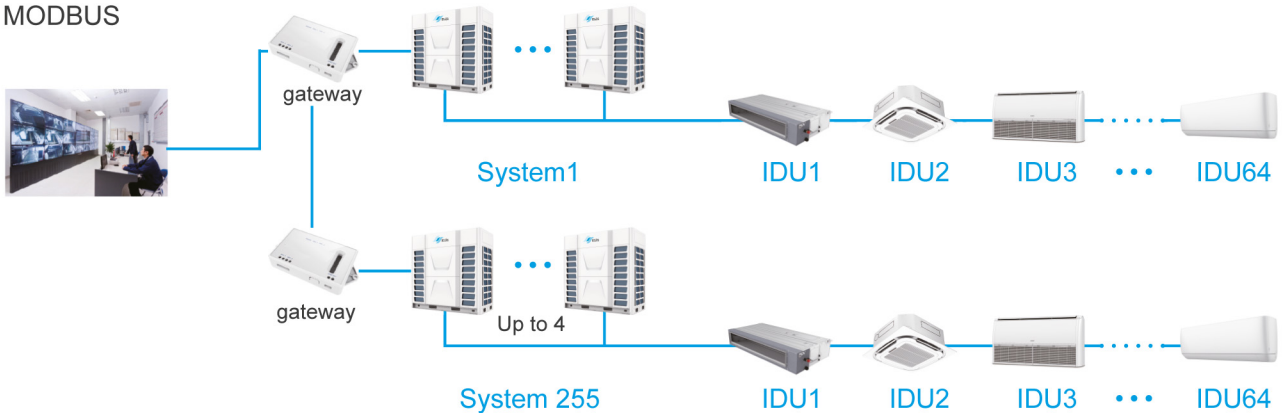



Notes:

The master outdoor unit can also directly connect to MODBUS without mini gateway.
For details, please contact MANDO technical engineers

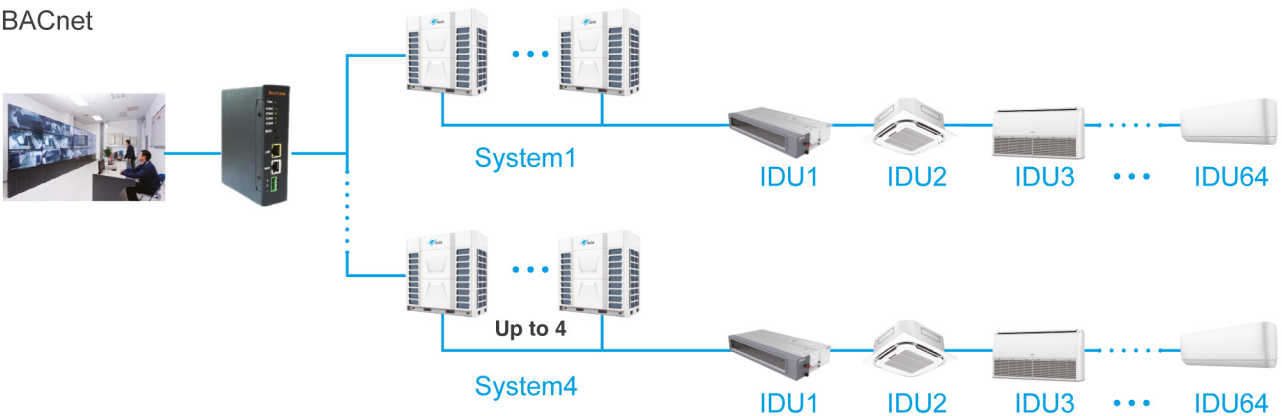
BACnet



Model	CM-MTD/AM01	Bacnet gateway
		
Dimension(W×H×D)mm	127 ×65.8×20.8	115×35×135
Power supply	DC 12V	DC 24V,7W
Feature	Max.255	Unlimited(HUB)

Wireless Network Control

► Schematic Diagram

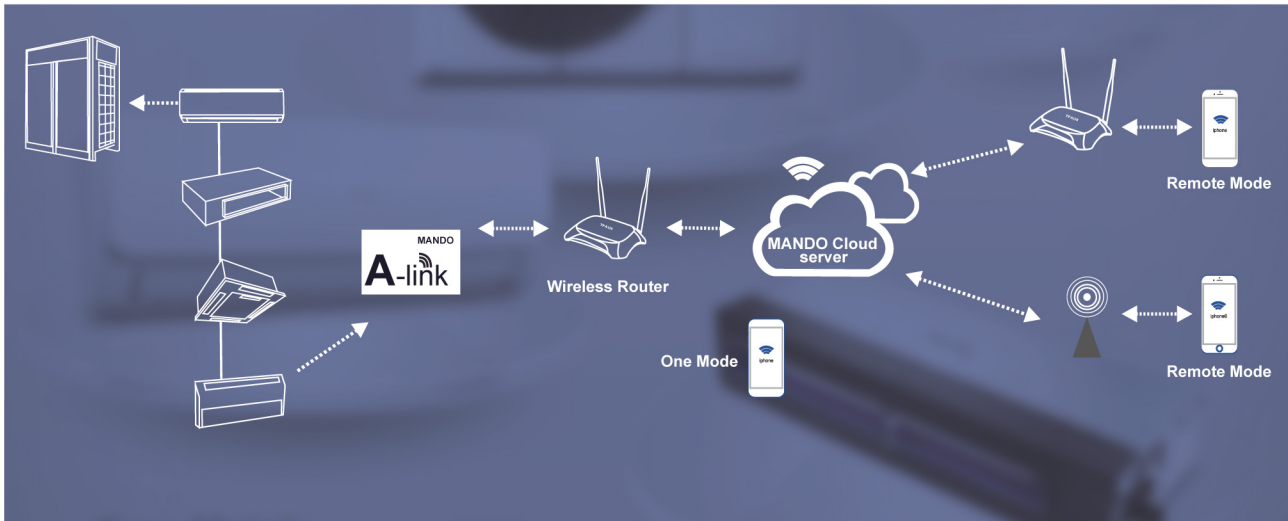

► Features

1. MANDO air conditioner can connect to intelligent terminal through WIFI or GPRS network, customers can enjoy fun and convenience of remote control the AC via iphone, ipad and other mobile terminals(Android and IOS) at anytime and anywhere.
2. The function of software on Mobile terminal includes mode control, temperature control, swing control, timing control.
3. Customers can set schedule to plan their day, also the scene mode can be set conveniently.

Accessories-AHU Kit



Model	AHU Capacity	Net Dimension (W×D×H)mm	Packing Dimension (W×D×H)mm	Net Weight (kg)	Gross Weight (kg)	DX coil volume (min-max)dm ³	Reference air volume(m ³ /h)	Power supply		
ARVK-0B	2.2~3.6	573×447×180	655×525×250	10.9	13.4	0.4~0.45	550	220-240V,50,1		
	3.6~4.5					0.45~0.55	600			
	4.5~5.6					0.55~0.65	750			
	5.6~7.1					0.65~0.75	900			
	7.1~8.0					0.75~1.2	1000			
	8.0~9.0					1.2~1.66	1300			
ARVK-00B	9.0~11.2			11.2	13.8	11.3	13.9		1.66~2.06	1400
	11.2~14.0								2.06~2.58	2000
	14.0~16.0								2.58~3.22	2400
	16.0~20.0								3.32~3.69	2700
ARVK-01B	20.0~25.0			11.3	13.9	11.6	14.3		3.7~4.6	3000
	25.0~30.0								4.6~5.5	3800
ARVK-02B	30.0~36.0			11.6	14.3	11.8	14.6		5.6~6.6	4500
	36.0~40.0								6.6~7.4	5500
	40.0~45.0								7.4~8.3	6000
ARVK-03B	45.0~50.0			11.8	14.6	11.8	14.6		8.3~9.2	7000
	50.0~56.0								9.2~10.3	8000
	56.0~65.0								9.63~11.56	8200
	65.0~70.0								11.03~12.54	9400
	70.0~76.0								11.90~13.30	10200
	76.0~80.0								12.62~14.01	10800
	80.0~90.0								13.40~15.26	11800
	90.0~100.0								15.26~17.80	13400
100.0~112.0	17.51~19.61			15000						

Remarks: applicable to MINI VRF (capacity ≥ 12KW)

Remarks:

- 1.Data may change according to test surroundings, reserves right of explanation on data.
- 2.All specifications are subject to change by the manufacturer without prior notice.

► Single AHU connection

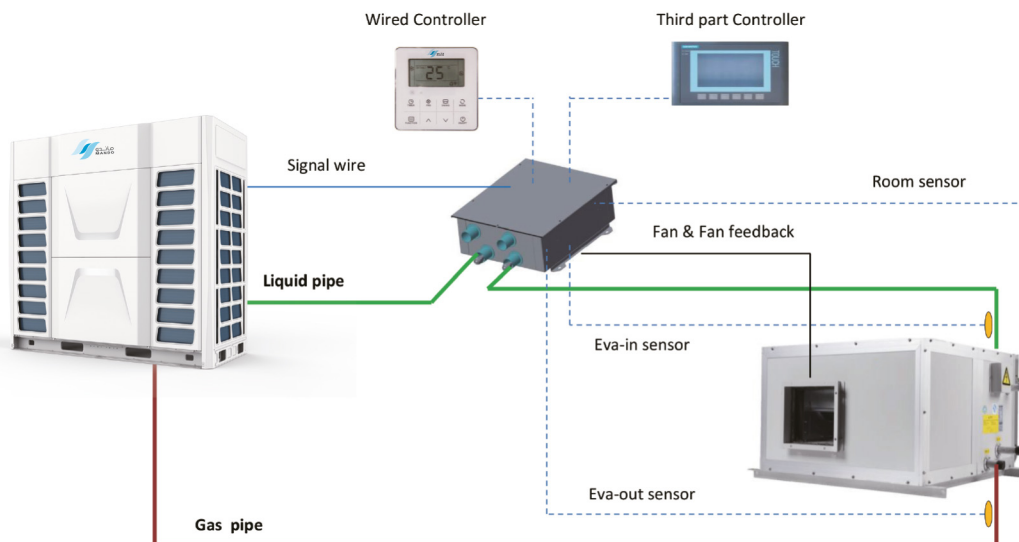

Above diagram suitable for factory default control, 0-10V(temperature control), 0-10V(pressure control)

► Multi AHU connection

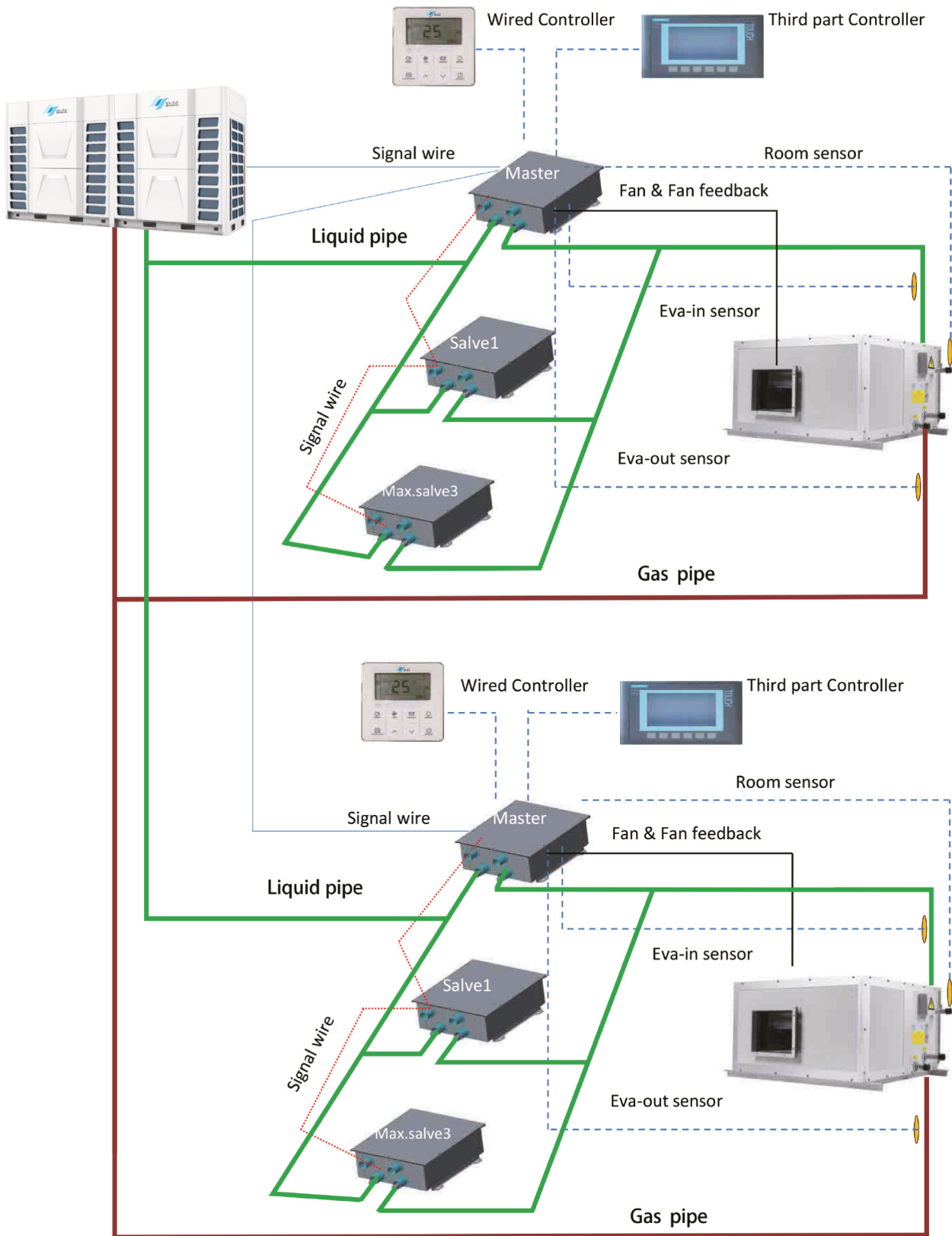

Above diagram suitable for factory default control, 0-10V(temperature control)

Accessories-Selection Software

To meet the customers' requirements, MANDO has developed the advanced selection software. The software provides quick and convenient selectable options for users, supports multiple languages, greatly improves the selection and installation process.

► 6 Parts Of The MANDO M7 Selection

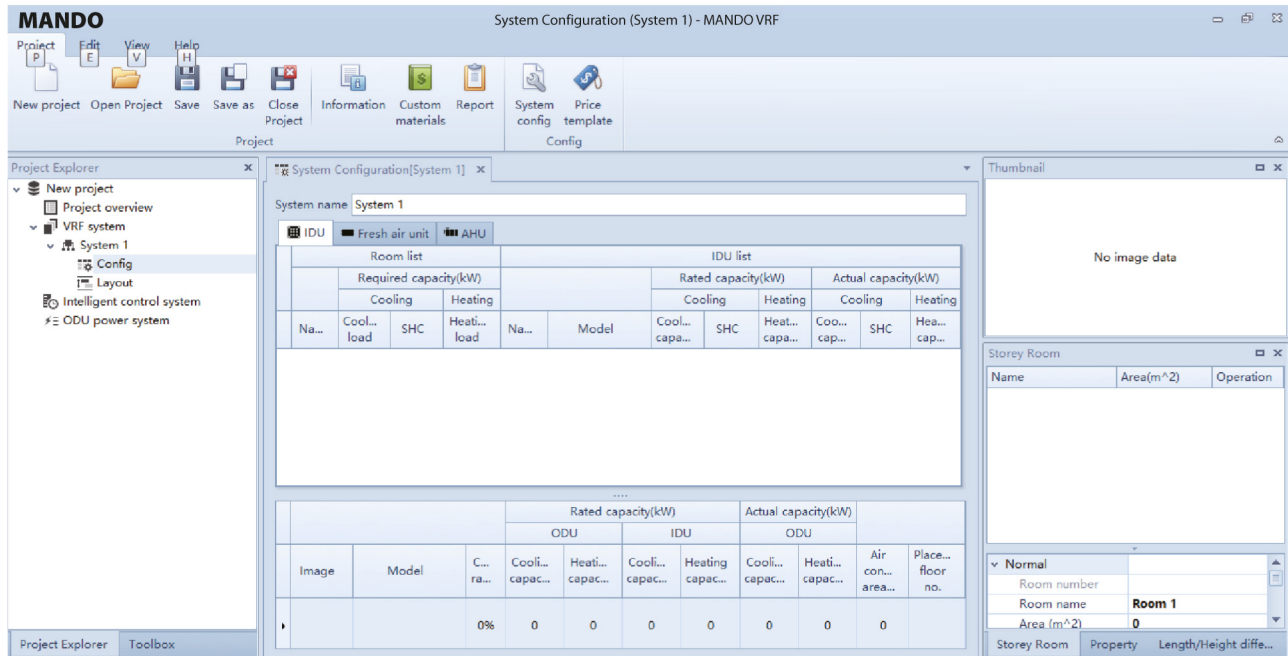

► Revit Models Series

Revit is developed to make 3D design (shows Electrical Connector+Pipe Connectors +Produce parameter) of MANDO products easier than the previous program. It enables engineers to check 3D images from design stage and prevents possible issues of the installation stage.

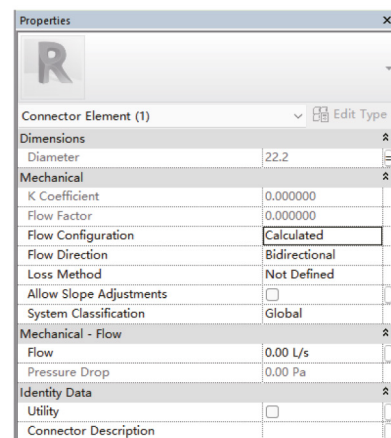
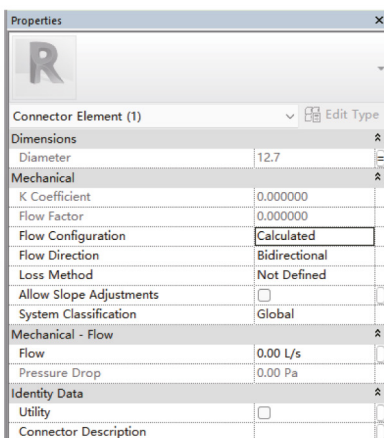

Accessories-Monitoring Software

Self-diagnosis software can be used as remote controller, it is recommended for commissioning. It can monitor the running state of the outdoor and indoor units real time. And display the malfunctions, be convenient to do the commissioning and trouble-shooting work.

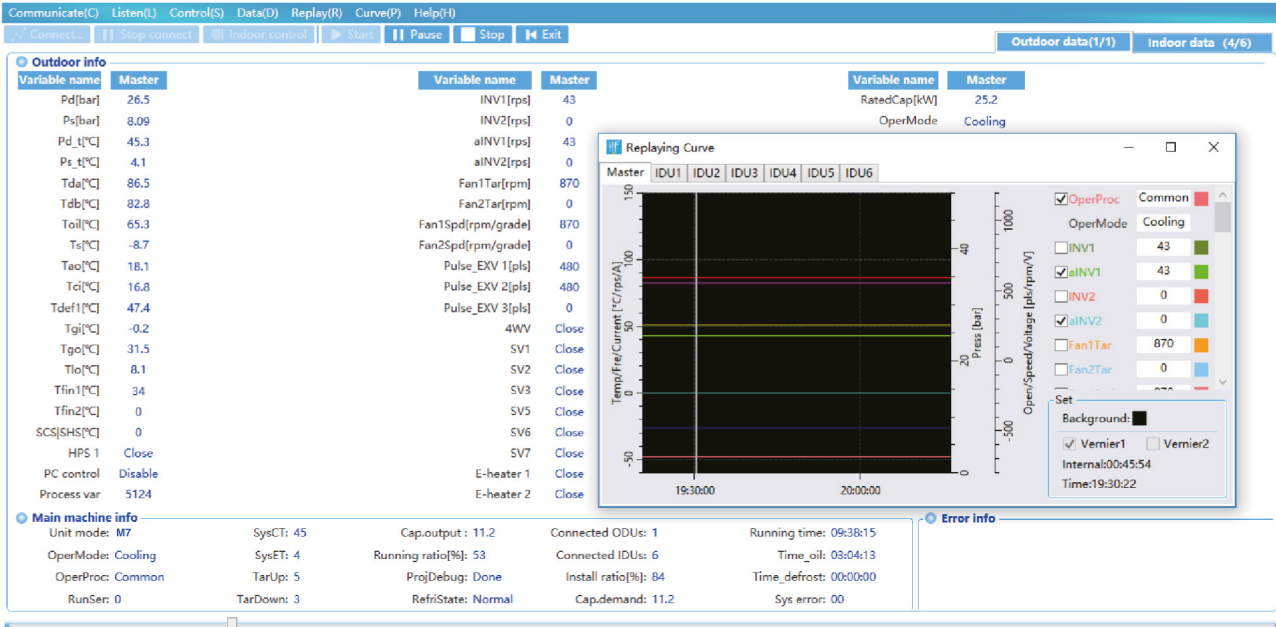

Monitoring Software

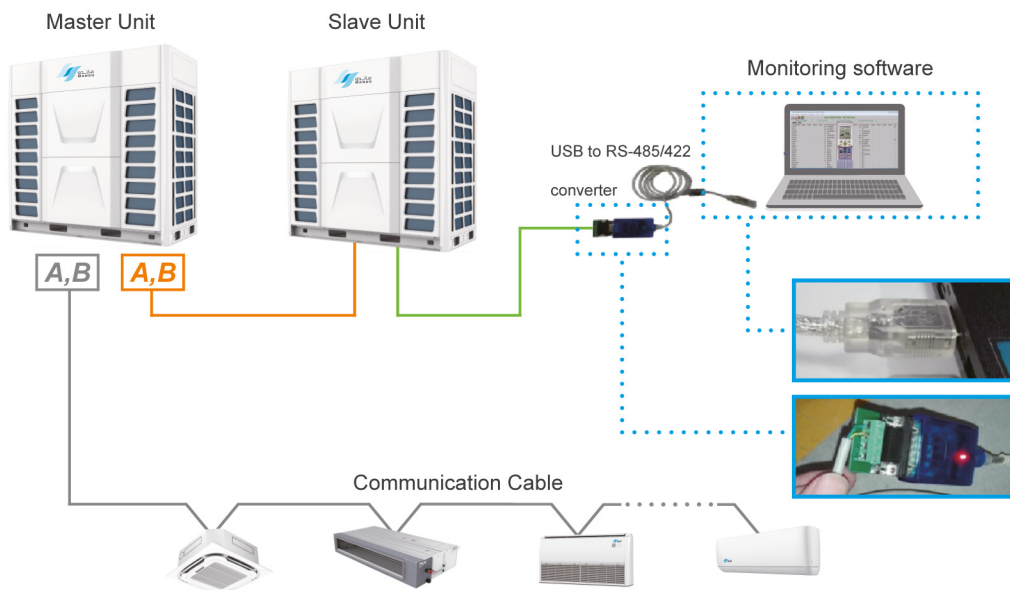

Installation Diagram

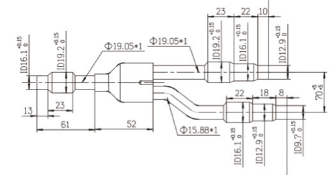
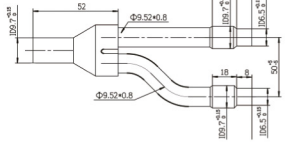
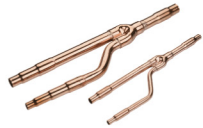
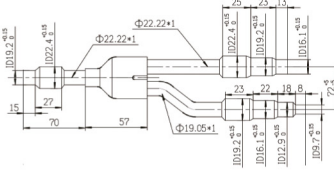
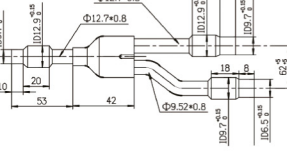
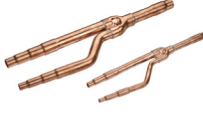
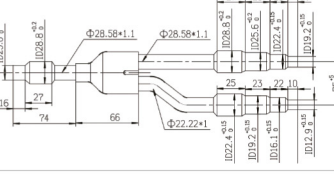
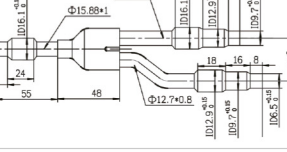
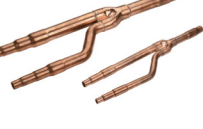
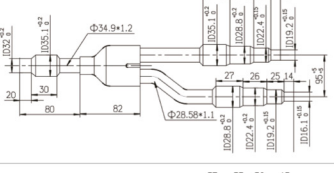
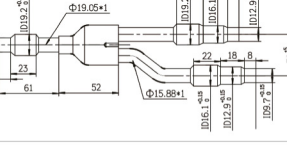

Branch Pipe

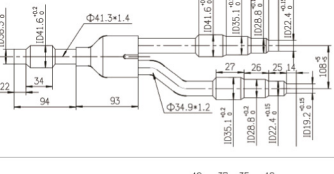
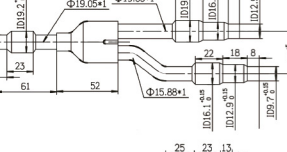
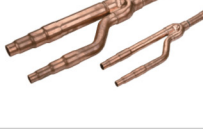
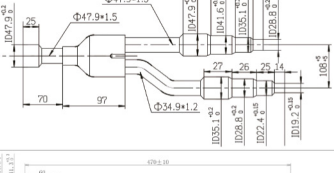
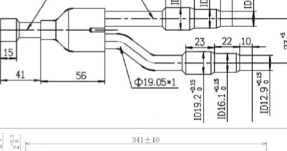
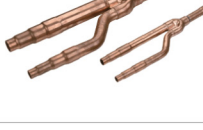
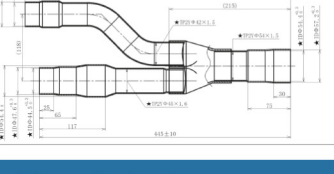
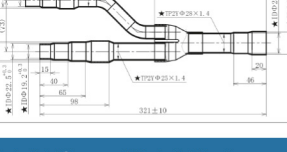
Model	Appearance	Dimension	
		Gas side joints	Liquid side joints
AFG-00B			
AFG-12B			
AFG-24B			
AFG-34B			
AFG-50B			
AFG-64B			
AFG-144B			
Model	Packing Dimension(mm)		Net Weight/Gross Weight(kg)
AFG-00B	300x95x40		0.31/0.35
AFG-12B	330x100x40		0.44/0.49
AFG-24B	370x115x45		0.71/0.77
AFG-34B	440x140x50		1.11/1.20
AFG-50B	480x160x65		1.65/1.76
AFG-64B	480x160x65		1.88/1.98
AFG-144B	505x180x80		2.49/2.62

A*: The total capacity of indoor units which is connected to this branch joint



ماندو - شركة فاريز للتجارة و التسويق
Mando - Fareaz for Trading & Marketing Co.Ltd

الرياض - المملكة العربية السعودية - الرقم الموحد # ٨٠١٢٤٠٤٠٢
Riyadh - Kingdom of Saudi Arabia - Unified # 8001240402

@MANDO_SAUDI
MANDO.COM.SA

